



ISTRUZIONI DI MONTAGGIO

IT

FITTING INSTRUCTIONS

EN

NOTICE DE MONTAGE

FR

عيميچت لالتاميلعت

AR

AQUA CAKE

6XX - 7XX



WE ARE IB

DATI TECNICI

Pressione dinamica min: 0.5 bar

Pressione MAX di esercizio: 5 bar

Pressione di esercizio raccomandata: 1-5 bar

Si raccomanda di utilizzare un riduttore di pressione,
se all'interno dell'impianto si hanno pressioni statiche superiori a 5 bar.

Temperatura MAX acqua calda: 65°C

NORME DI INSTALLAZIONE, MANUTENZIONE E VERIFICHE PRELIMINARI

Perchè il suo apparecchio funzioni nella maniera corretta e possa durare nel tempo, occorre che vengano rispettate le modalità di installazione e manutenzione illustrate in questo opuscolo. Affidarsi ad un idraulico qualificato. Assicurarsi che l'impianto sia stato liberato da tutti i detriti ed impurità esistenti.

PULIZIA

Per una corretta pulizia, lavare esclusivamente con acqua e sapone, risciacquare ed asciugare con una pelle di daino e panno morbido. Evitare assolutamente l'impiego di alcool, solventi, detersivi solidi o liquidi contenenti sostanze corrosive o acide, strofinacci con fibre sintetiche, spugne abrasive, tamponi con fili metallici, poichè potrebbero alterare irreversibilmente le superfici trattate.

L'UTILIZZO DI QUESTO TIPO DI DETERGENTI PER LA PULIZIA DEL RUBINETTO FA DECADERE QUALSIASI GARANZIA SULLA SUPERFICIE DELLO STESSO DA PARTE DI IB.

TECHNICAL DATA

Minimum dynamic pressure: 0.5 bar

Maximum operational pressure: 5 bar

Recommended operational pressure: 1-5 bar

It's recommended to use a pressure reducer in case of
static pressure superior than 5 bar inside the waterpipe.

Maximum hot water temperature: 65°C

INSTALLATION, MAINTENANCE AND PRELIMINARY CHECKING PROCEDURE

In order to get your device work correctly and fine in time, must ensure compliance with the mode of installation and maintenance described in this booklet. Relying on a qualified plumber. Make sure that the system is free from all debris and impurities existing.

CLEANING

In order to obtain a correct cleanliness, exclusively wash them with soap and water, rewash and dry them with a soft towel and deerskin. Avoid the usage of alcohol, solvents, solid or liquid detergents which contain corrosive or acidic substances, abrasive sponges, swab with metallic strings because they could irreversibly compromise the surfaces.

THE USAGE OF THIS KIND OF DETERGENTS DURING THE CLEANING OF THE MIXER EXCLUDE IB RUBINETTERIE FROM ANY WARRANTY OBLIGATION.

CARACTERISTIQUES TECHNIQUES

Pression dynamique minimale : 0.5 bar

Pression de service maximale : 5 bar

Pression de service recommandée : 1-5 bar

Il est recommandé d'utiliser un réducteur de pression en cas,

dans le système hydraulique, il y a des pressions statiques supérieures à 5 bar.

Température maximum d'eau chaude : 65°C

INSTALLATION, D'ENTRETIEN ET VÉRIFICATIONS PRÉLIMINAIRES

Pour assurer le bon fonctionnement du produit et il puisse durer dans le temps, il est nécessaire qu'ils soient remplies les procédures de installation et l'entretien définies dans la brochure. S'appuyer sur un plombier qualifié. S'assures que les tuyauteries soient nettoyées par toutes saletés et résidus.

NETTOYAGE

Afin d'assurer un bon nettoyage, laver exclusivement avec eau et savon, rincer et essuyer avec un chiffon doux. N'utiliser jamais alcool, solvants, de poudres à récurer ni de nettoyeurs acides et éponges abrasives ou éponges métalliques car risquent de causer des dommages irrémediables.

L'UTILISE DES CES DETERGENTS POUR LE NETTOYAGE DU MITIGEUR REND CADUQUE LA GARANTIE SUR LA SURFACE DE-CI PAR IB.

ةي نقت تامول عم

راب 0.5 يكي ماني دلا طغض لل يندألا دحل

راب 5 لي غشتلا طغض لي صقالا دحل

راب 1-5 : هب لي صوملا لي غشتلا طغضلا

كلذ شودح لاج يي طغضلا ضفخم م ادختساب لي صوي

ةشي شلا ل خاد راب 5 م لي عأ تباث طغض

ةي وئيم ةجرد 80 : نخاسلا ءاملا ةرارح ةجردل لي صقالا دحل

لي ولألا ص ح فل اءارچ او ةناي صل او تي ب ث تلا

اذه يي ح ضوملا ةناي صل او تي ب ث تلا عضول لا ث م الما نم دكأ تال بجي ، بس انم لاقولو يي و حي حص لك شب كزاه ج لم عي كي

ةدوجوملا بئ او شلا و ما طحل اعي مچ نم ما ظنلا ولخ نم دكأت . لهؤم كابس لي ع دامتعالا . بي ت كلال

في ظنن

لا زغال دلجو ةمغان ةف ش نمب اهف ج و اهلسغ دعأ م : نوب اصل او ءاملاب أي رصح اهلسغا ، ةحي حص ةفاظن لي ع لوصح ل لجانم

ةي ضمح وأ لكأ تال ةب بس م داوم لي ع يوتحت يتلا ةلئاسلا وأ ةب لصللا تا فظنم لاقو تابي ذم لاقو لوح كلال م ادختساب نجت

مهيف ةعجر ال لك شب حطسالا رضت نأ نكي م انهأل ةي ندعم لاقو طوي خلال تا ذت اح س م لاقو ةطش كلال تا جنفس لاقو

مازتلا يي أنم IB RUBINETTERIE ينثتسي طالخلل في ظنن ءانثأ تا فظنم لاقو نم عونلا اذه م ادختساب نإ

نماض لاقو

1

Ø48 mm - 1.89 in

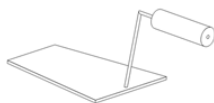
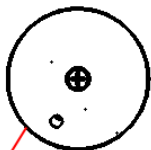

Ø65 mm - 2.56 in

91 mm - 3.58 in

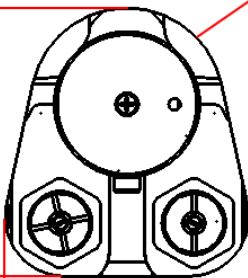

82 mm - 3.23 in

2

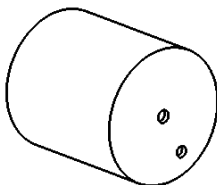
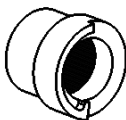
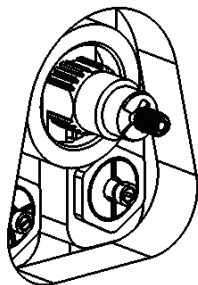
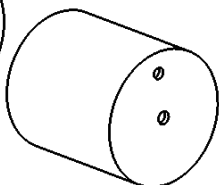

3

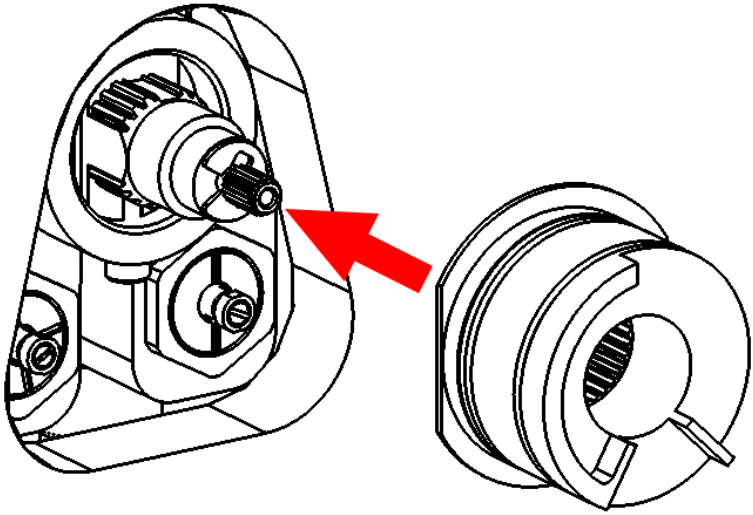

4

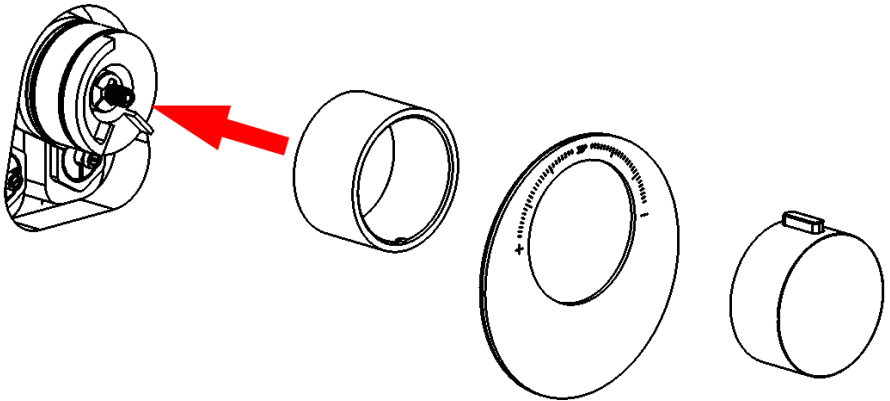

5

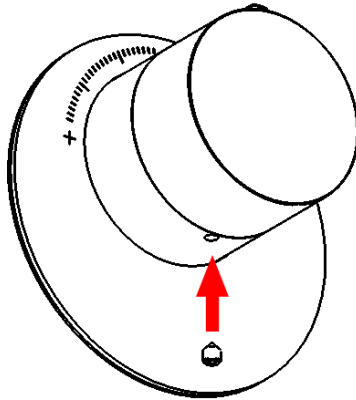

6



Se sporge tagliare a il filetto in modo che sia a filo del muro
If it protrudes, cut the thread so that it's flush with the wall
S'il dépasse, couper le filetage afin qu'il soit affleurant au mur
إذا كان بارزاً، اقطع القلاووظ بحيث يكون بمستوى الحائط

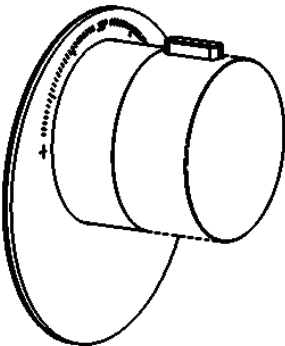

7

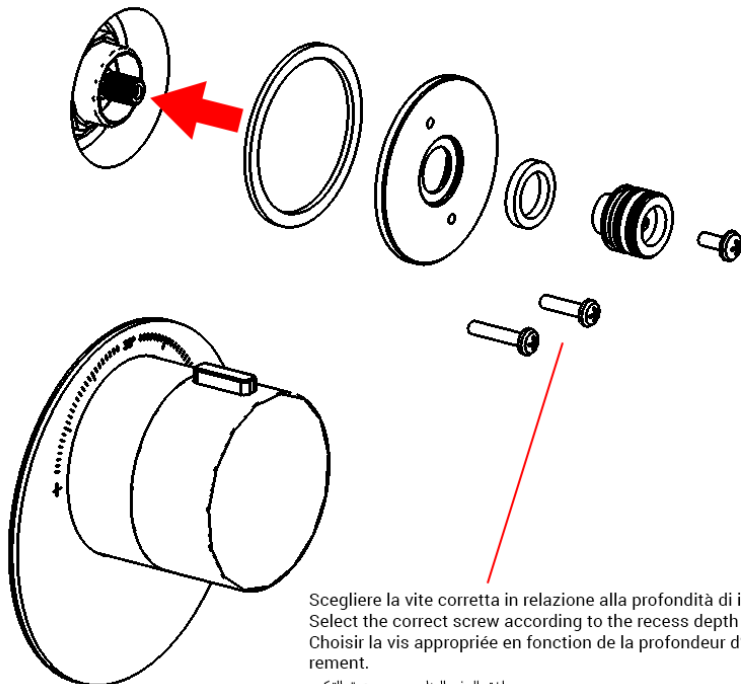

Scegliere la vite corretta in relazione alla profondità di incasso
Select the correct screw according to the recess depth
Choisir la vis appropriée en fonction de la profondeur d'encastrement.

اختر البرغي المناسب حسب عمق التركيب.

8

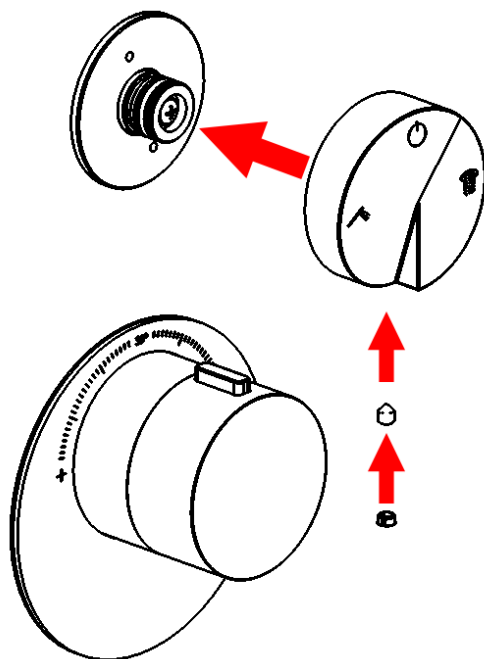

CALIBRAZIONE FERMO TEMPERATURA

Svitare i grani, estrarre la prima maniglia, svitare le vite e sfilare la seconda maniglia. Verificare la corretta calibrazione del fermo temperatura ruotando la seconda maniglia fin contro al fermo, collocare un termometro sotto l'acqua corrente e controllare che la temperatura sia di 38°C. Se non corrisponde ruotare manualmente la broccia della cartuccia fino ad ottenere i 38°C. Reinscrivere il fermo temperatura e verificare che quando la maniglia raggiunge il punto di fermo si abbiano sia la temperatura di 38°C che l'allineamento con il logo sulla piastra. Procedere al contrario per rimontare.

ADJUSTING THE TEMPERATURE STOP

Unscrew the grub screw, remove the first handle, undo the screw and remove the second handle. Check that the temperature stop is set correctly by turning the handle to the stop, place a thermometer in the water flowing from the outlet and check that the temperature is 38°C. If this is not the case, turn the cartridge's spindle by hand until 38°C. Put the temperature stop back in place and check that when the handle reaches the stop the temperature is 38°C and the handle is aligned with the marking on the plate. Reverse the above procedure to reassemble.

ÉTALONNAGE DU LOQUET DE TEMPÉRATURE

Dévisser la petite vis, extraire le poigne, dévisser les petites vis et extraire le croisillon. Vérifier le correct étalonnage de la molette en tournant le croisillon jusqu'à le loquet, sonder la température de l'eau à sa sortie à l'aide d'un thermomètre et s'assurer qu'il soit 38°C. Si cela ne correspond pas, tourner la broche de la cartouche manuellement jusqu'à atteindre le 38°C. Réinsérer la molette et vérifier que lorsque le croisillon atteint le loquet il soit à 38°C et aussi aligné au logo sur la platine. Pour le remontage, procéder dans l'ordre inverse.

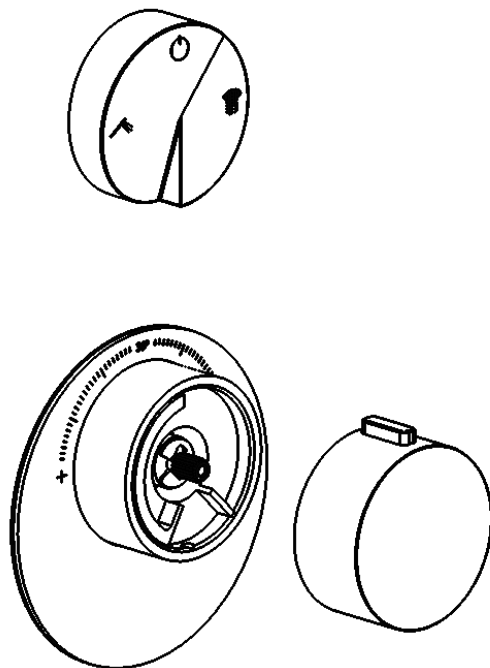

SMONTAGGIO CARTUCCIA TERMOSTATICA E DEVIATORE

Smontaggio cartuccia termostatica: chiudere le entrate dell'acqua. Svitare i grani, estrarre la maniglia, svitare la vite, estrarre la maniglia, sfilare la piastra, estrarre il fermo di temperatura, svitare l'anello ed il grano, estrarre la cartuccia. Per il montaggio procedere in ordine inverso, assicurandosi che la sede del grano sia posizionata in corrispondenza del foro e che le sedi interne di tenuta siano accuratamente pulite.

Smontaggio cartuccia deviatore: chiudere le entrate dell'acqua. Svitare i grani, estrarre le maniglie, svitare la vite, estrarre la maniglia e la broccia, sfilare la piastra, estrarre la bussola di sostegno, svitare l'anello, le due ghiera filettate e la ghiera.

Estrarre la cartuccia. Per il montaggio procedere in ordine inverso, assicurandosi che il piano d'appoggio della guarnizione sia accuratamente pulito.

REMOVING THE THERMOSTATIC CARTRIDGE AND DIVERTER

Thermostatic cartridge disassembly: shut off the water inlets. Unscrew the grub screw, remove the handle, undo the screw, remove the handle, take off the plate, remove support sockets, remove the temperature stop, unscrew the ring and the grub screw and remove the cartridge. To reassemble, reverse the above procedure, making sure that the grub screw seat is aligned with the hole and the internal seal seats are thoroughly cleaned.

Diverter cartridge disassembly: Turn off the water inlets. Unscrew the grub screw, remove the handle, undo the screw, remove the handles and the broach, take off the plate, remove support sockets, unscrew the ring, the two threaded ring nuts and the ring nut. To reassemble, reverse the above procedure, making sure the gasket contact surface is thoroughly cleaned.

DÉMONTAGE DE LA CARTOUCHE THERMOSTATIQUE ET DE LE DEVIATEUR

Démontage de la cartouche thermostatique : couper l'alimentation en eau. Dévisser les petites vis, enlever la poignée, dévisser la petite vis, enlever le croisillon, enlever la plaque, enlever les bagues de support et le commande pour arrêter la température, dévisser l'anneau et la petite vis, extraire la cartouche. Pour le montage, procéder dans l'ordre inverse en assurant que le logement de la petite vis se place en correspondance du trou et que les sièges internes d'étanchéité soient bien nettoyés.

Démontage de la cartouche: Couper l'alimentation en eau. Dévisser les petites vis, enlever la poignée, dévisser la petite vis, enlever le croisillon et la broche, enlever la plaque, extraire la bague de support, dévisser l'anneau, les deux les deux bagues filetées et l'écrou annulaire. Extraire la cartouche Pour le montage, procéder dans l'ordre inverse en assurant que le siège de logement du joint torique soit bien nettoyé.

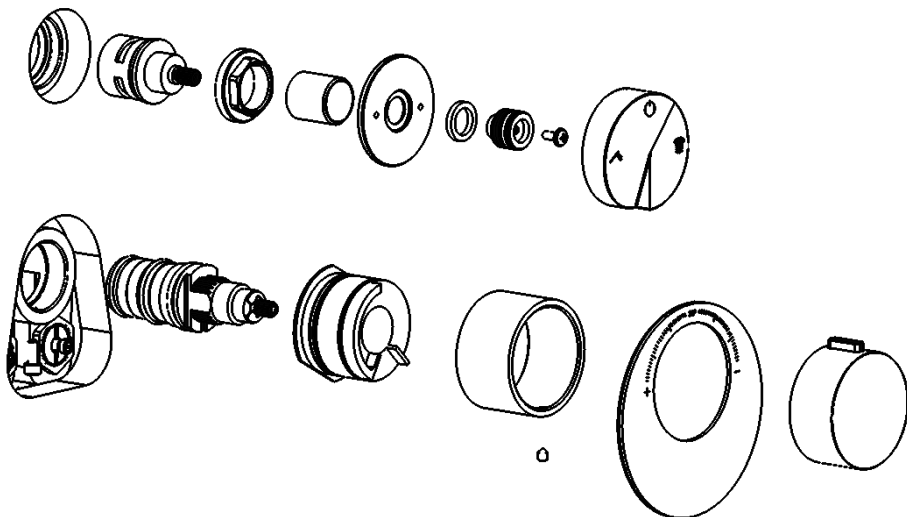

SMONTAGGIO VALVOLE DI NON RITORNO

Chiudere le entrate dell'acqua. Svitare i grani, rimuovere la maniglia, svitare la vite, sfilare la maniglia e la piastra, svitare le valvole di non ritorno con una chiave da 27 mm. Pulire la valvola dai residui di sporco sotto acqua corrente. Per il montaggio procedere in ordine inverso.

REMOVING THE CHECK VALVES

Turn off the water inlets. Unscrew the grub screw, remove the handle, undo the screw, remove the handle and the plate and unscrew the check valve with a 27 mm spanner. Wash off dirt residues under running water. To reassemble, reverse the above procedure.

DÉMONTAGE DES CLAPETS ANTI-RETOUR

Couper l'alimentation en eau. Dévisser les petites vis, enlever la poigne, dévisser la petite vis, enlever le croisillon, enlever la platine, dévisser les clapets en utilisant une clef de 27 mm. Rincer les têtes à clapet avec l'eau et purger toutes saletés et résidus. Pour le montage, procéder dans l'ordre inverse.

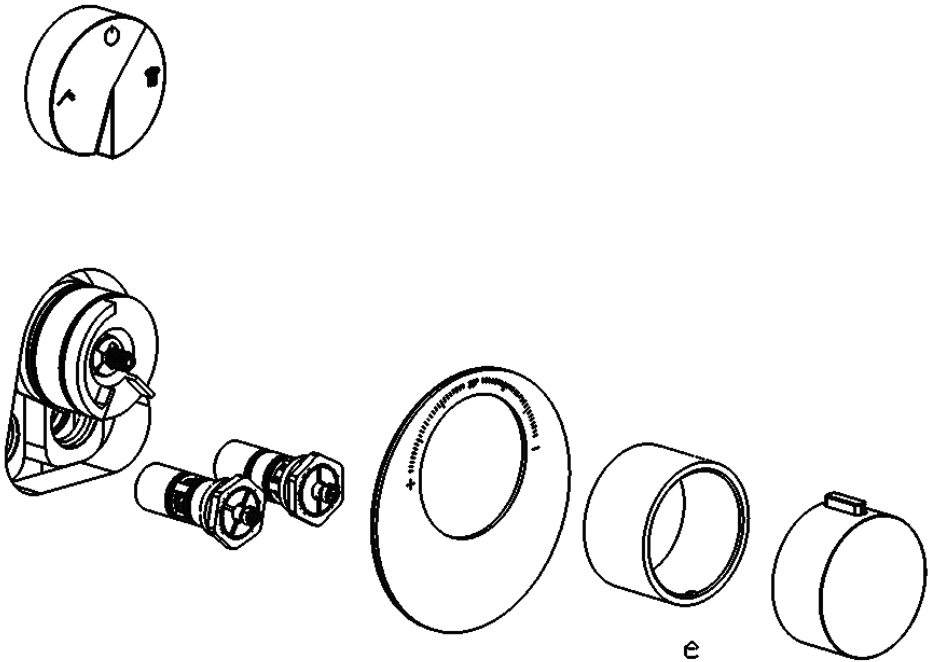

INVERTIRE VALVOLE

Se durante la realizzazione dell'impianto le due entrate dell'acqua calda e fredda, sono state invertite, ovvero se il tubo dell'acqua calda è posizionato a destra e non a sinistra, è possibile invertire l'ingresso dell'acqua nella cartuccia termostatica semplicemente invertendo di posizione le valvole di non ritorno, senza apportare modifiche all'impianto.

Chiudere le entrate dell'acqua. Svitare i grani, rimuovere la maniglia, svitare la vite, sfilare la maniglia e la piastra, svitare le valvole di non ritorno con una chiave da 27 mm. Invertire la posizione delle valvole. Per il montaggio procedere in ordine inverso. Effettuare una prova della corretta riuscita dell'operazione.

REVERSE VALVES

If during the construction of the system the inlets of hot and cold water, are inverted, in other words if the hot water pipe is positioned to the right and not to the left, it is possible to invert the inlet water into the thermostatic cartridge by simply reversing the position of non-return valves, without making any changes to the system.

Shut off the water. Undo the grub screw, remove the handle, undo the screw, extract the handle and the plate, unscrew the valves with a 27 mm spanner. Reverse the valves position. To reassemble, proceed in reverse order. Perform a test to verify the results of operation.

INVERSION CLAPETS ANTI-RETOUR

Si pendant le montage du thermostatique ont été inverties l'entrées en eau chaud et froide, donc si le tuyau de l'eau chaud est à la droite et non à gauche, c'est possible invtir l'alimentation en eau dans la cartouche en inversant les clapets anti-retour sans modifier le système hydraulique.

Couper l'alimentation en eau. Dévisser les petites vis, enlever la poigne, dévisser la petite vis, enlever le croisillon, enlever la platine, dévisser les clapets en utilisant une clef de 27 mm. Invertir l'emplacement des clapets anti-retour. Pour le montage, procéder dans l'ordre inverse. Après le remontage effectuer une vérification.

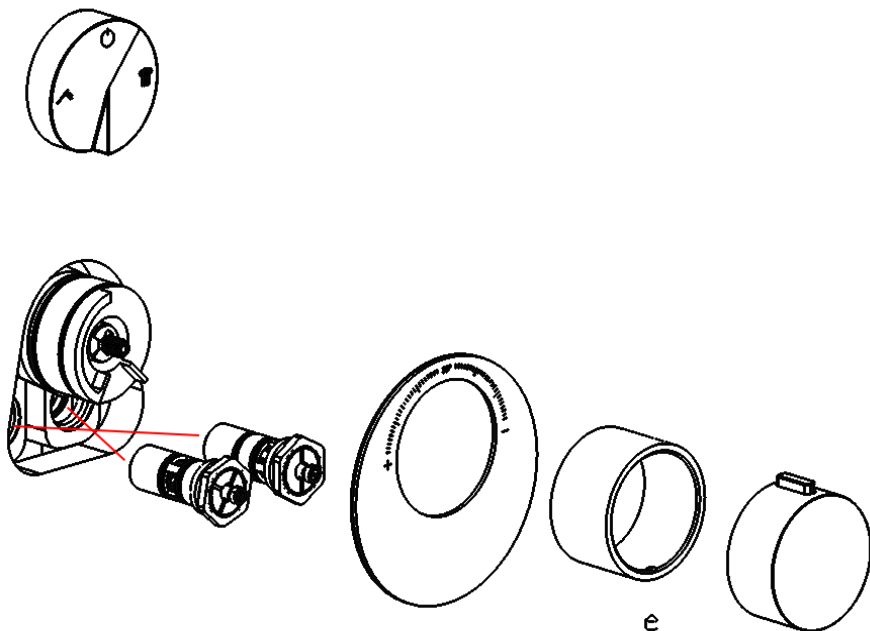

Rev.: 03/12/2025

IMPORTANT

Pressure & Temperature Requirements.

- ✿ Hot and cold water inlet pressures should be equal.
- ✿ Inlet pressure range: 150-1000 kPa
- ✿ New Regulation: -500 kPa maximum operating pressure at any outlet within a building. (Ref. AS/NZS 3500.1-2003, Clause 3.3.4)
- ✿ Maximum hot water temperature: 80°C.



WE ARE IB

IB RUBINETTERIE s.p.a
via dei Pianotti 3/5
25068 Sarezze (BS) - Italy -
P.IVA 01785230986

ISCR. REG. IMPR.
BS 01785230986
R.E.A. BS 352087
capitale sociale €420.000,00 i.v.

T. +39 030 802101
F. +39 030 803097
info@weareib.it
www.weareib.it