

1. De-installation of the panel  
Entfernung der Schürze

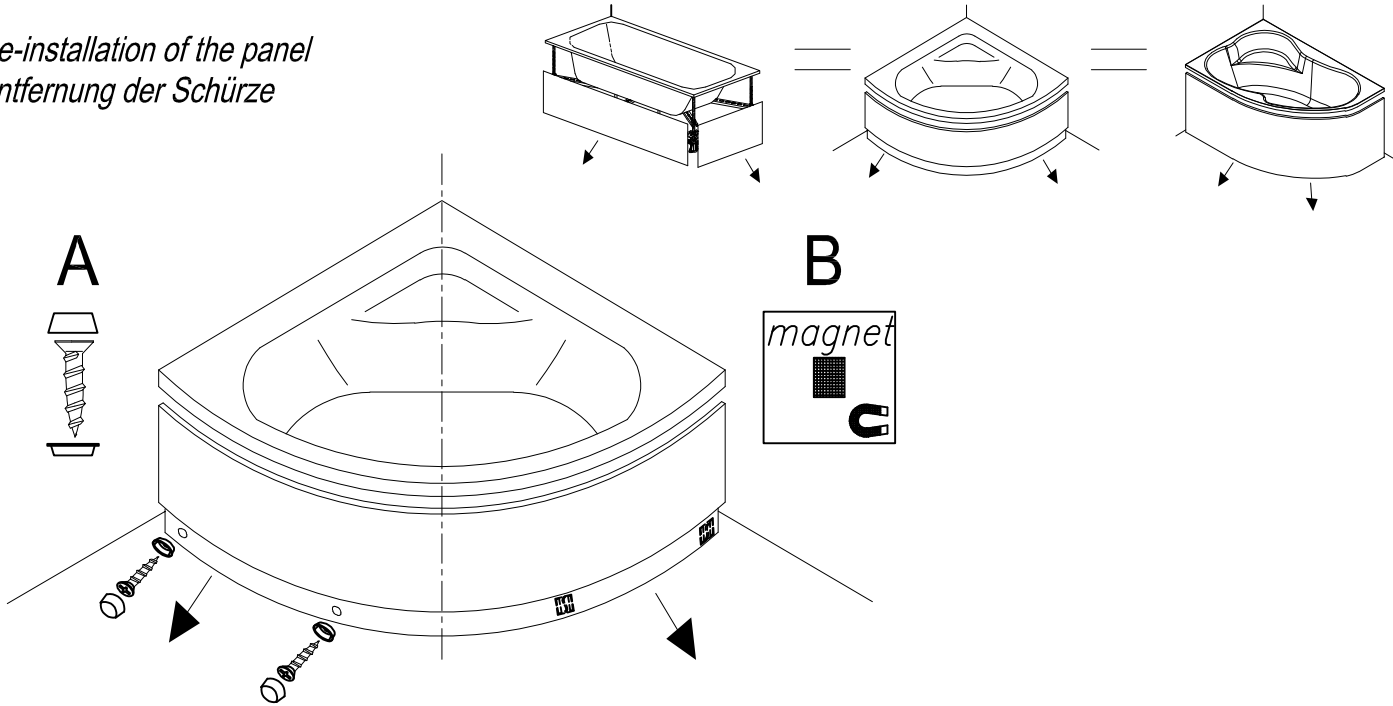

2. Levelling and marking of drilling sites  
Nivellierung und Bezeichnung von Bohrstellen

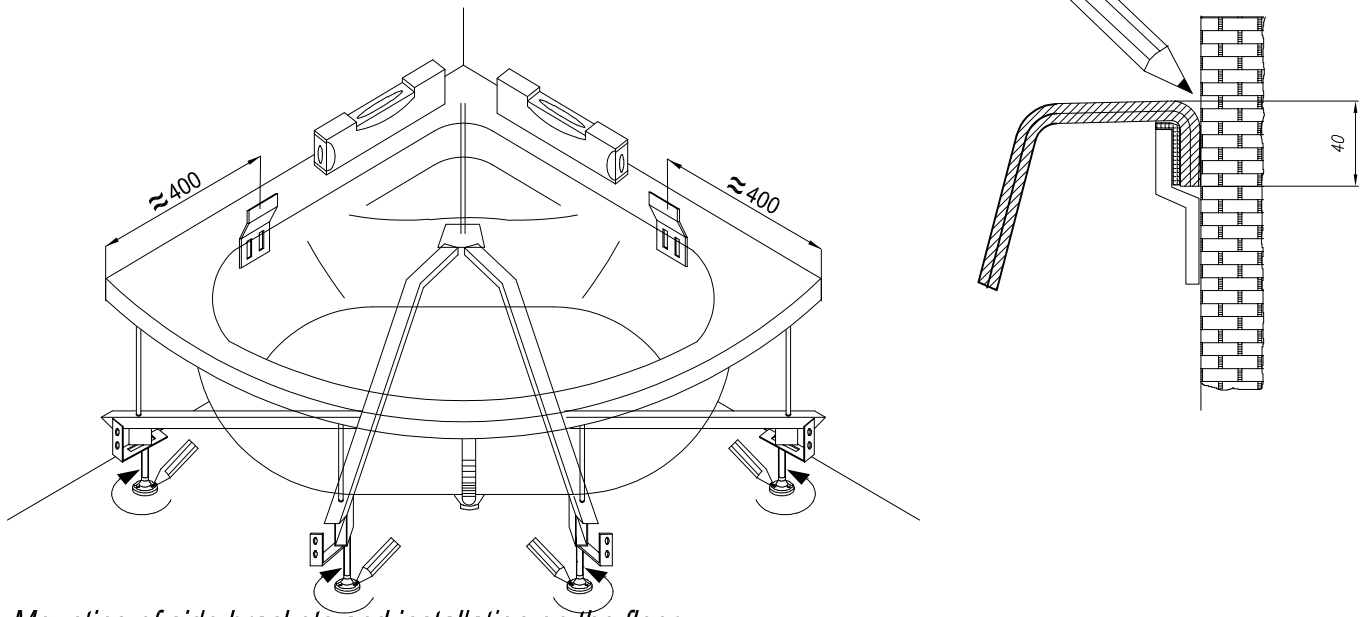

3. Mounting of side brackets and installation on the floor  
Befestigung von Wandträger und Befestigung am Boden

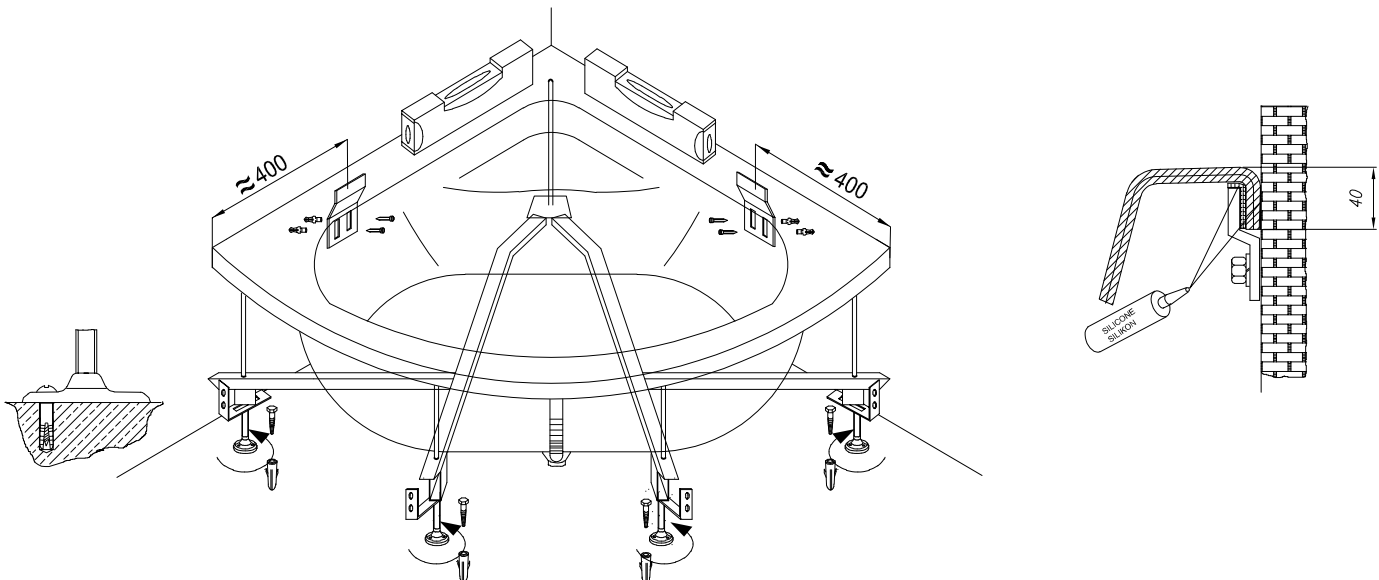

Installation of siphon  
Siphon-Montage

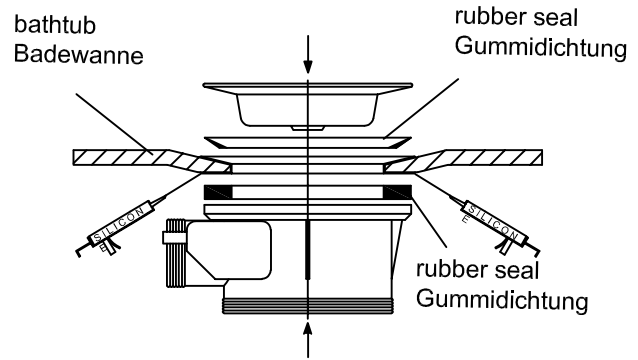
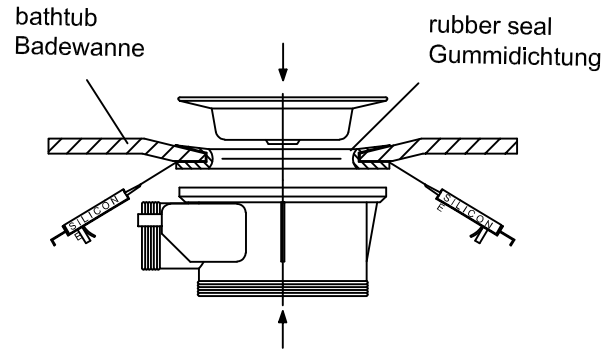
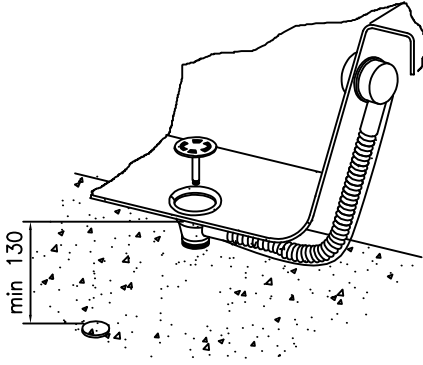

4. Mounting of the panel and siliconizing  
Montage von Schürze und Siliconieren

In case of the proposition of the panel due to an uneven wall, the panel needs to be cut to fit the appropriate measurement.  
Im Falle der zu lange Schürze wegen einer unebenen Wand muss die Schürze auf die entsprechende Maße verkürzt werden.

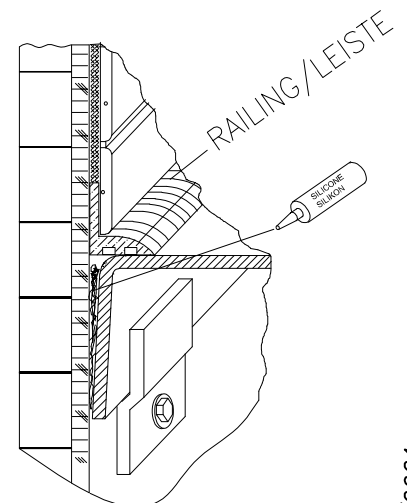
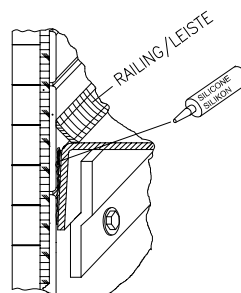
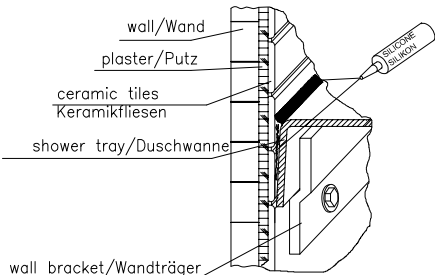
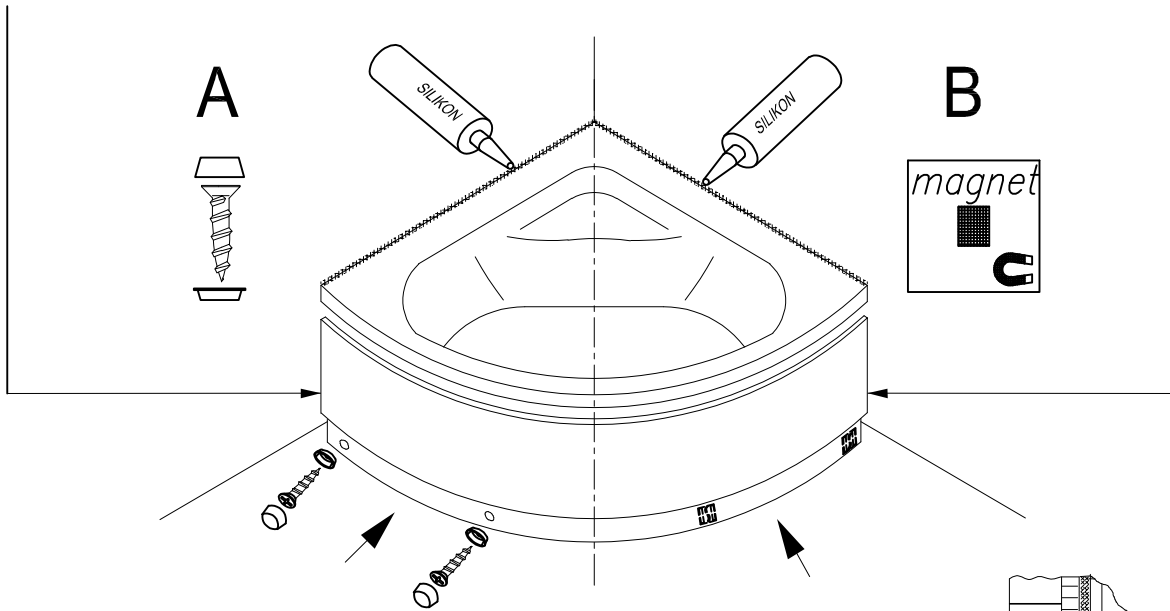

**VERSIONS OF BATHTUBS BUILT-IN BY THE WALL**  
**EINBAUVARIANTE AM WAND**

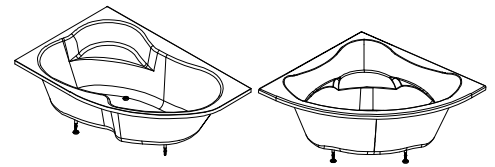

Construction element with the min. length of L=200mm, for optimal bearing capacity of the edge  
Baulement mit einer Mindestlänge von L = 200 mm für eine optimale Tragfähigkeit der Kante

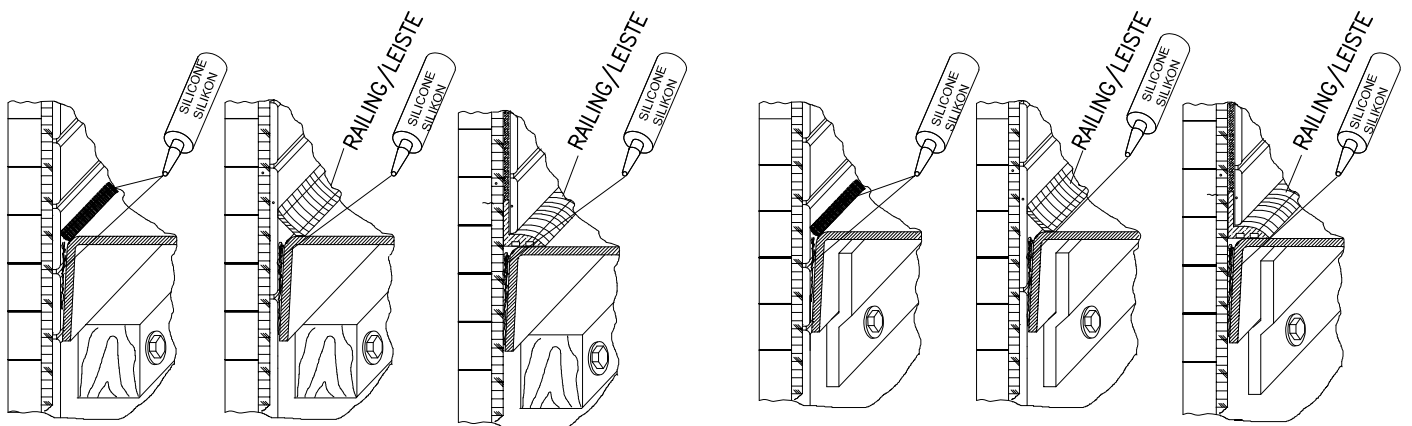
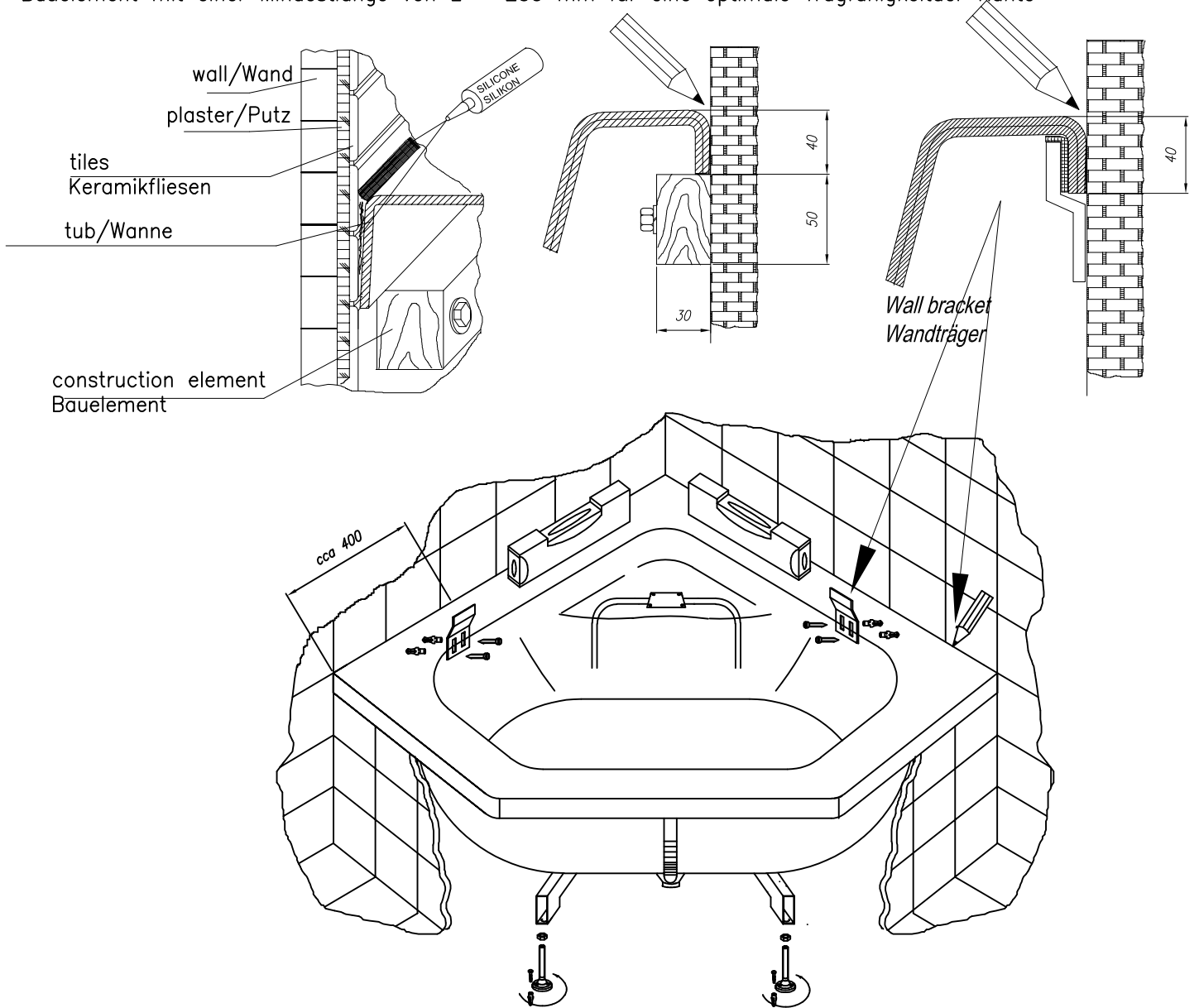

**FRONT INSTALLATION VARIANTS  
EINBAUVARIANTE DER VORDERSEITE**

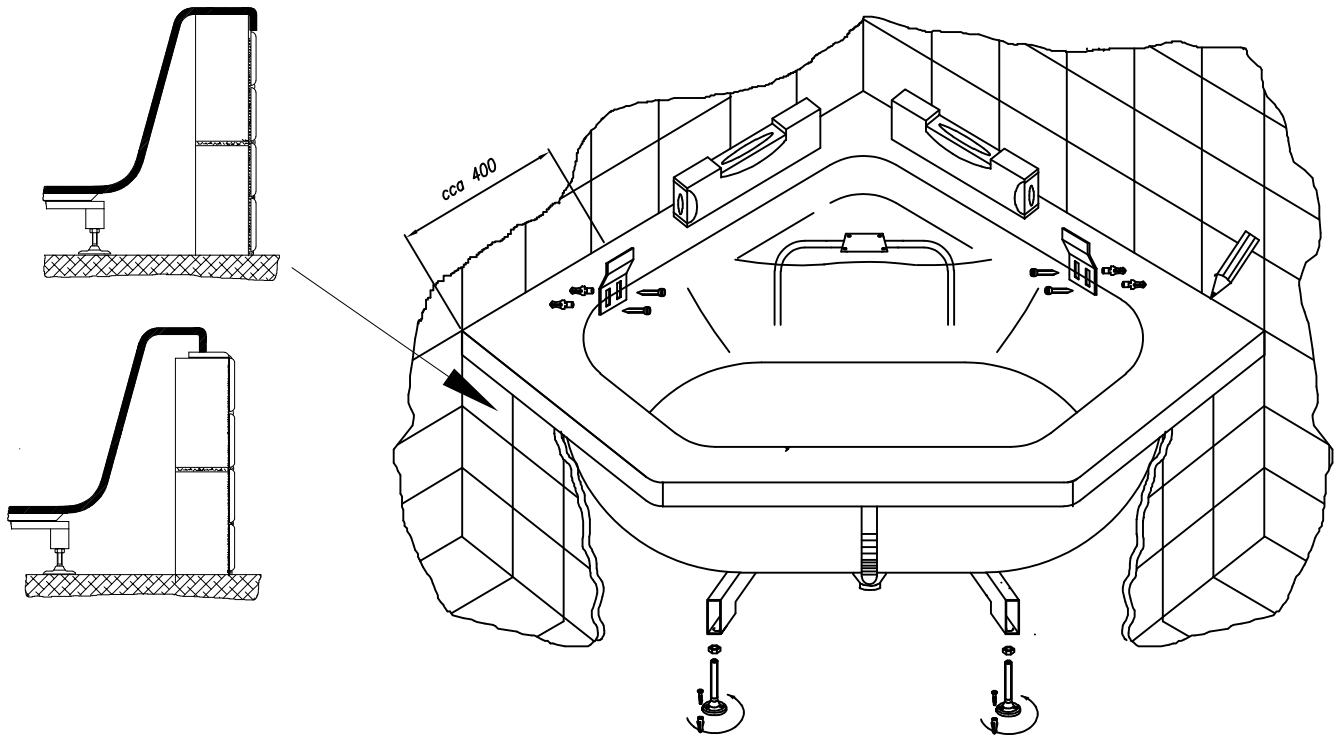

**MONTAŽA SIFONA  
MONTAŽA SIFONA**

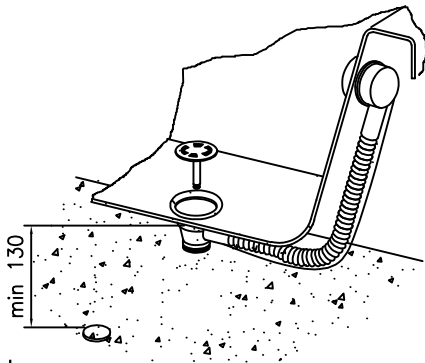

bathtub Badewanne rubber seal Gummidichtung

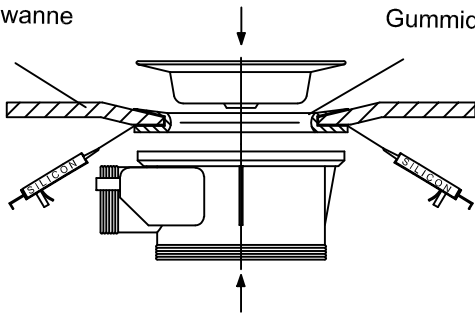

bathtub Badewanne rubber seal Gummidichtung

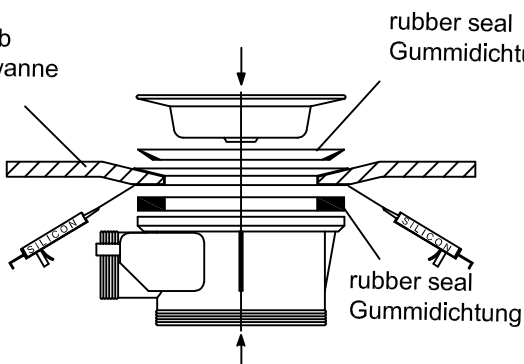

**INSTALLATION OF BASE  
SOCKELMONTAGE**

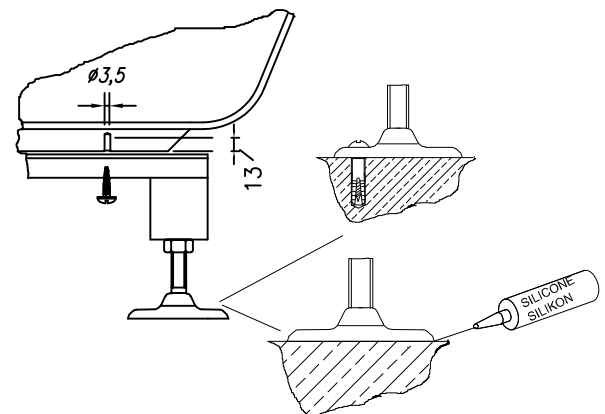

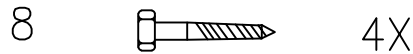
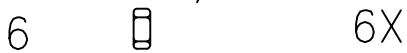
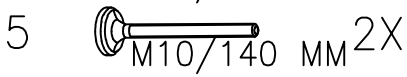
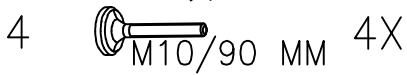
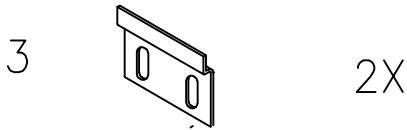
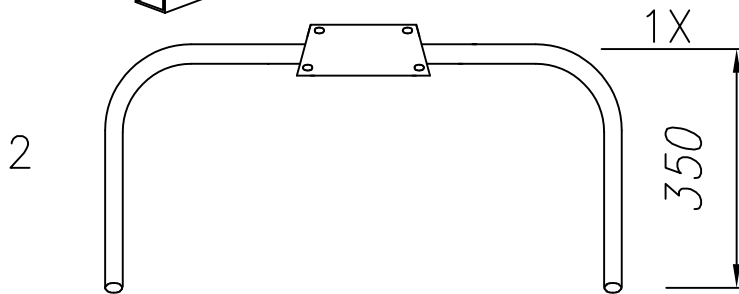
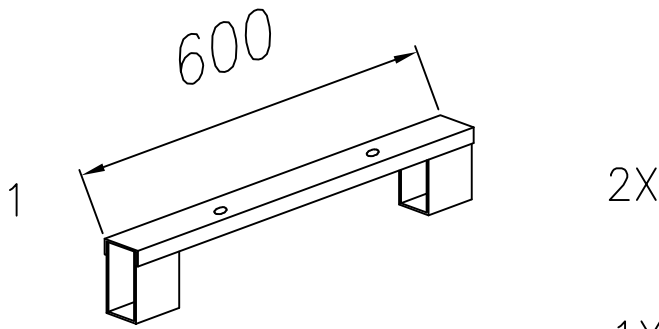

1.

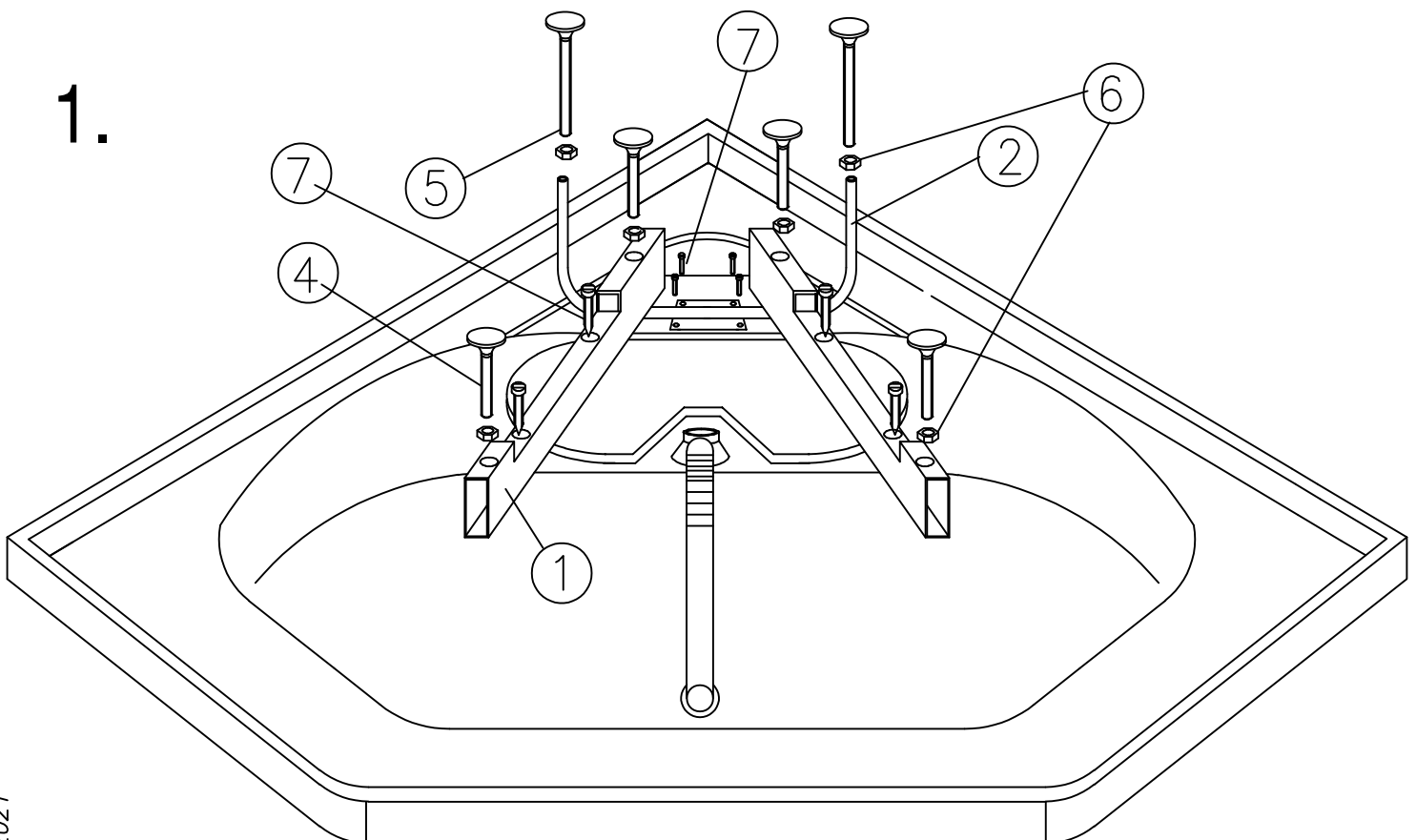

2.

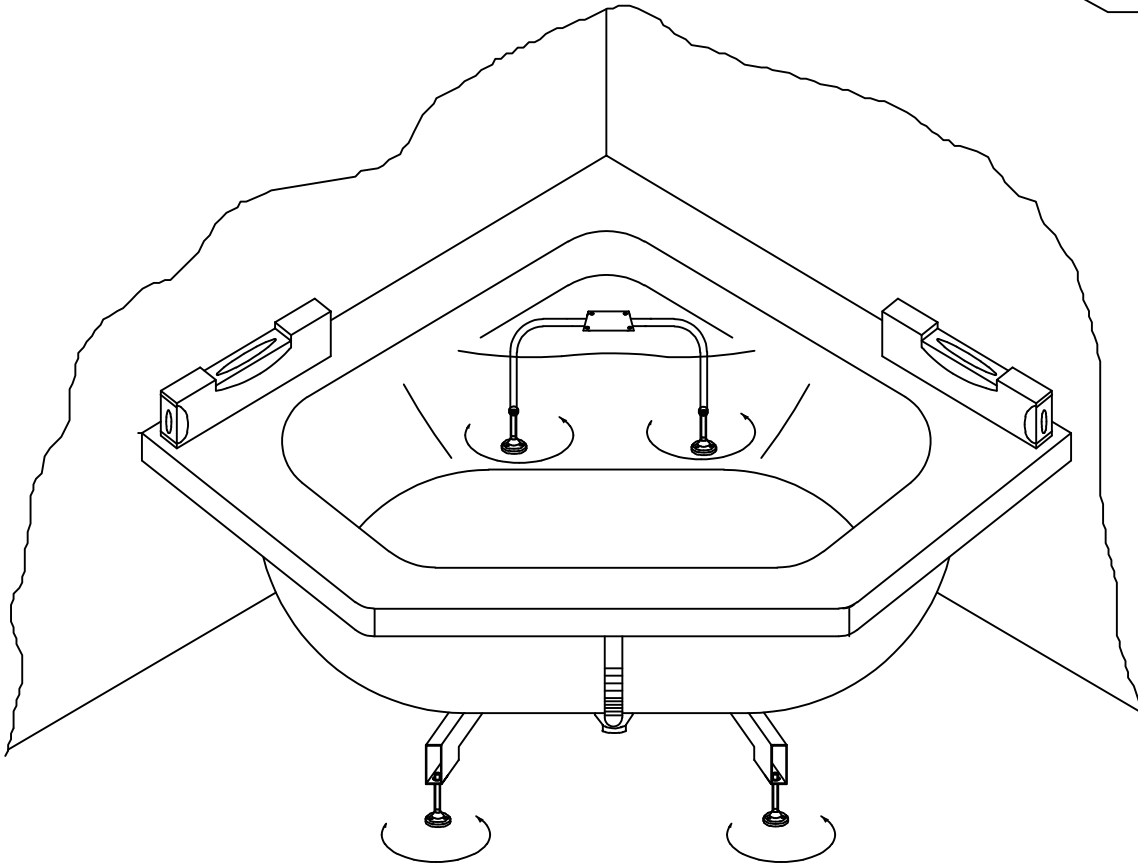

3.

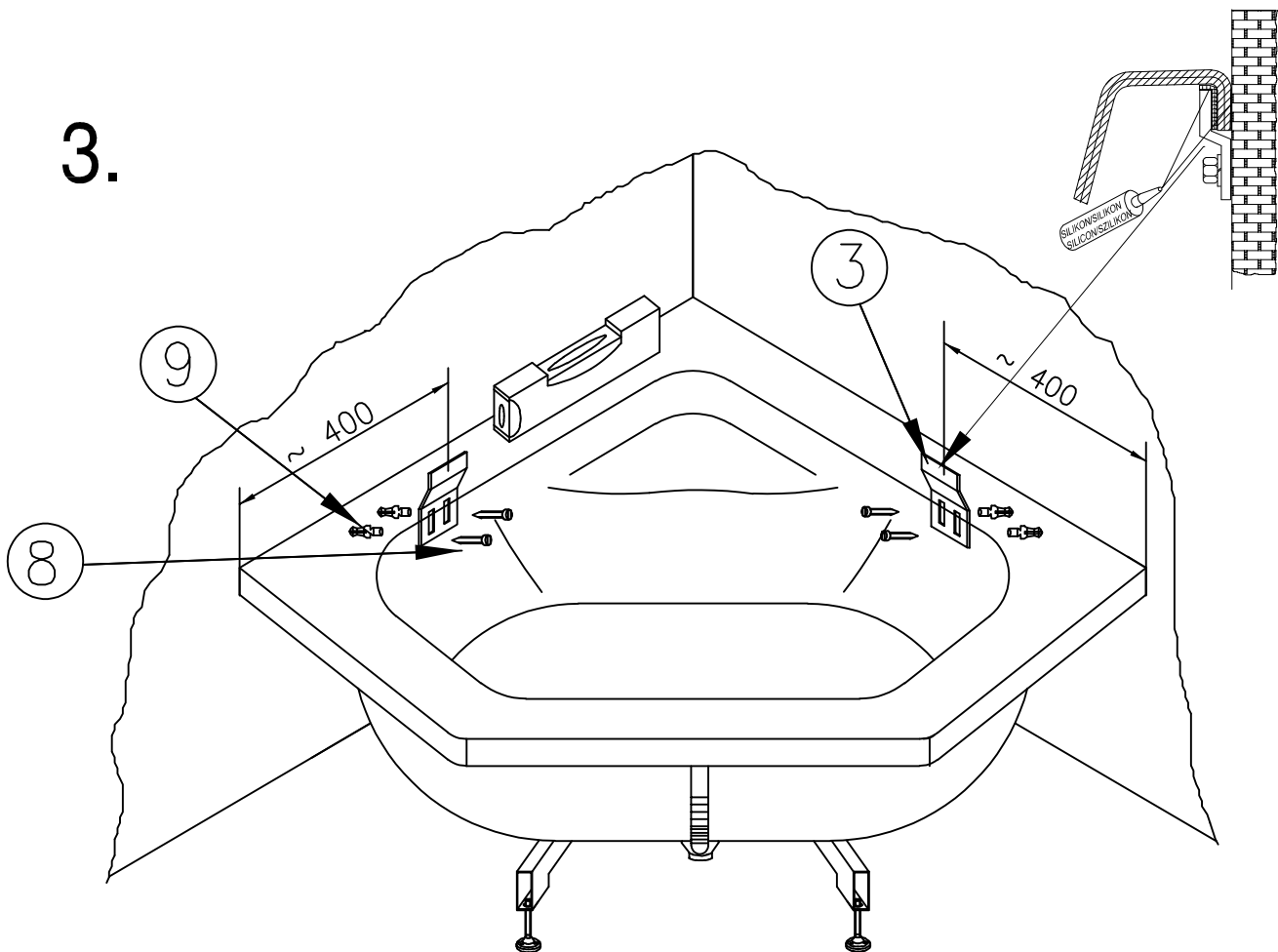

4/2023

# CKM120 - 150

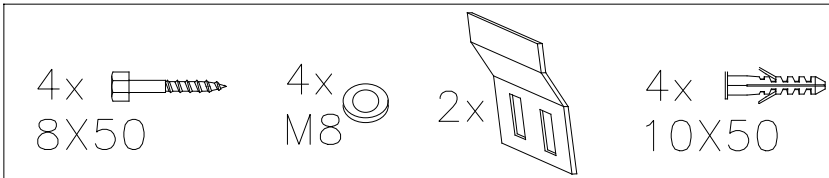
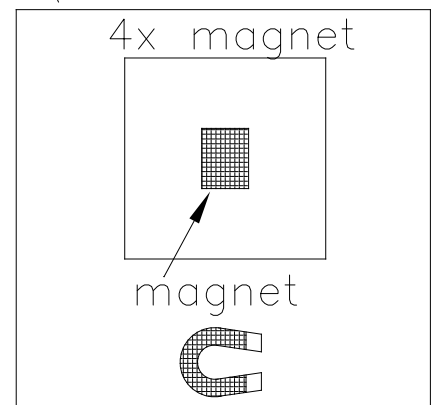
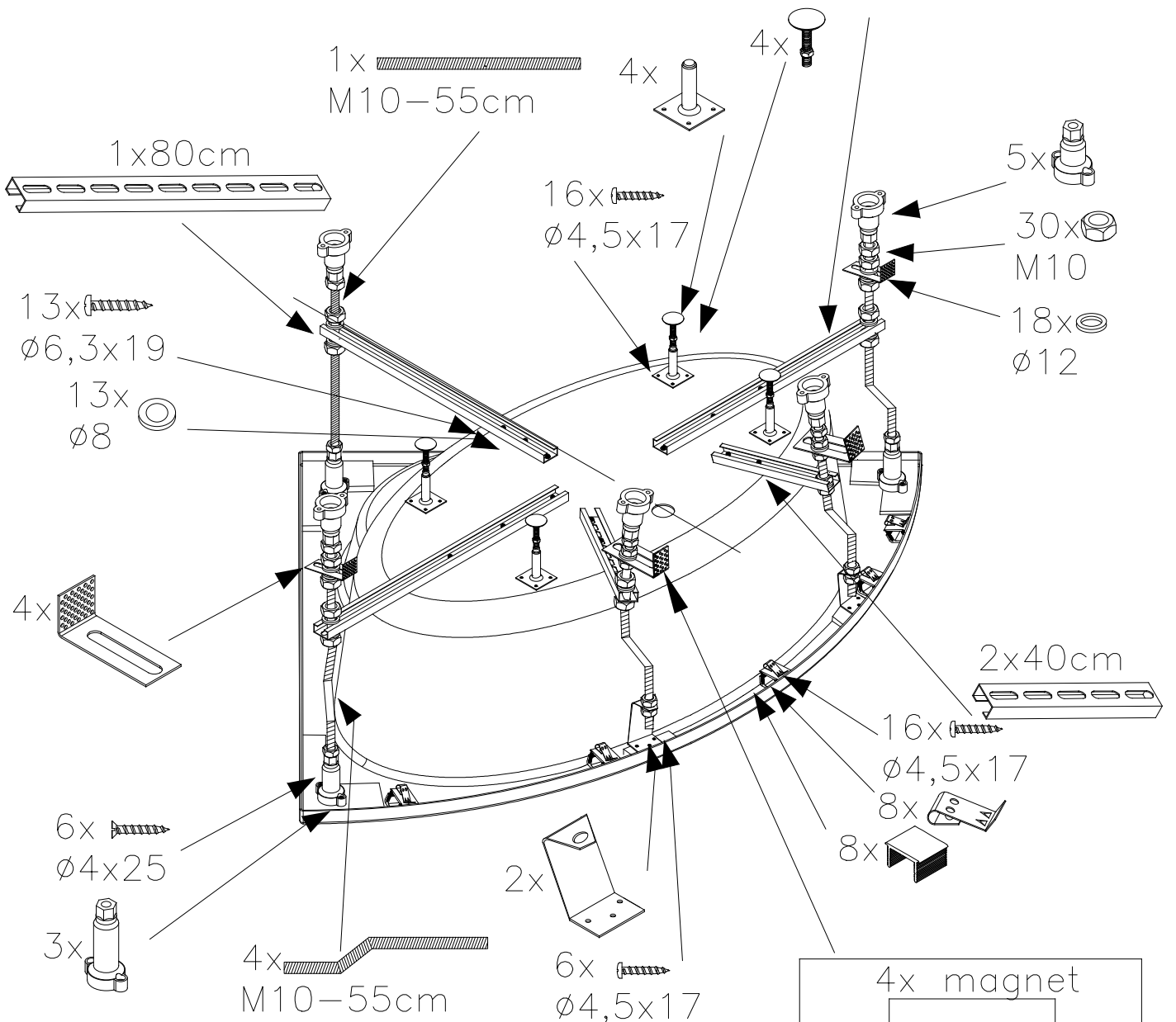
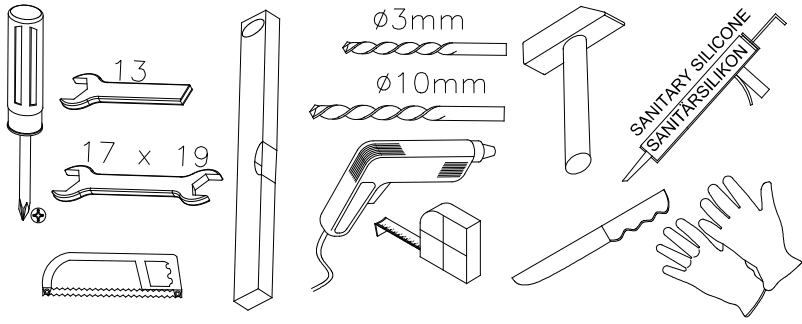
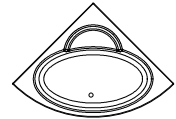

**STEP 1A**

DOLORES  
LIBRETTO

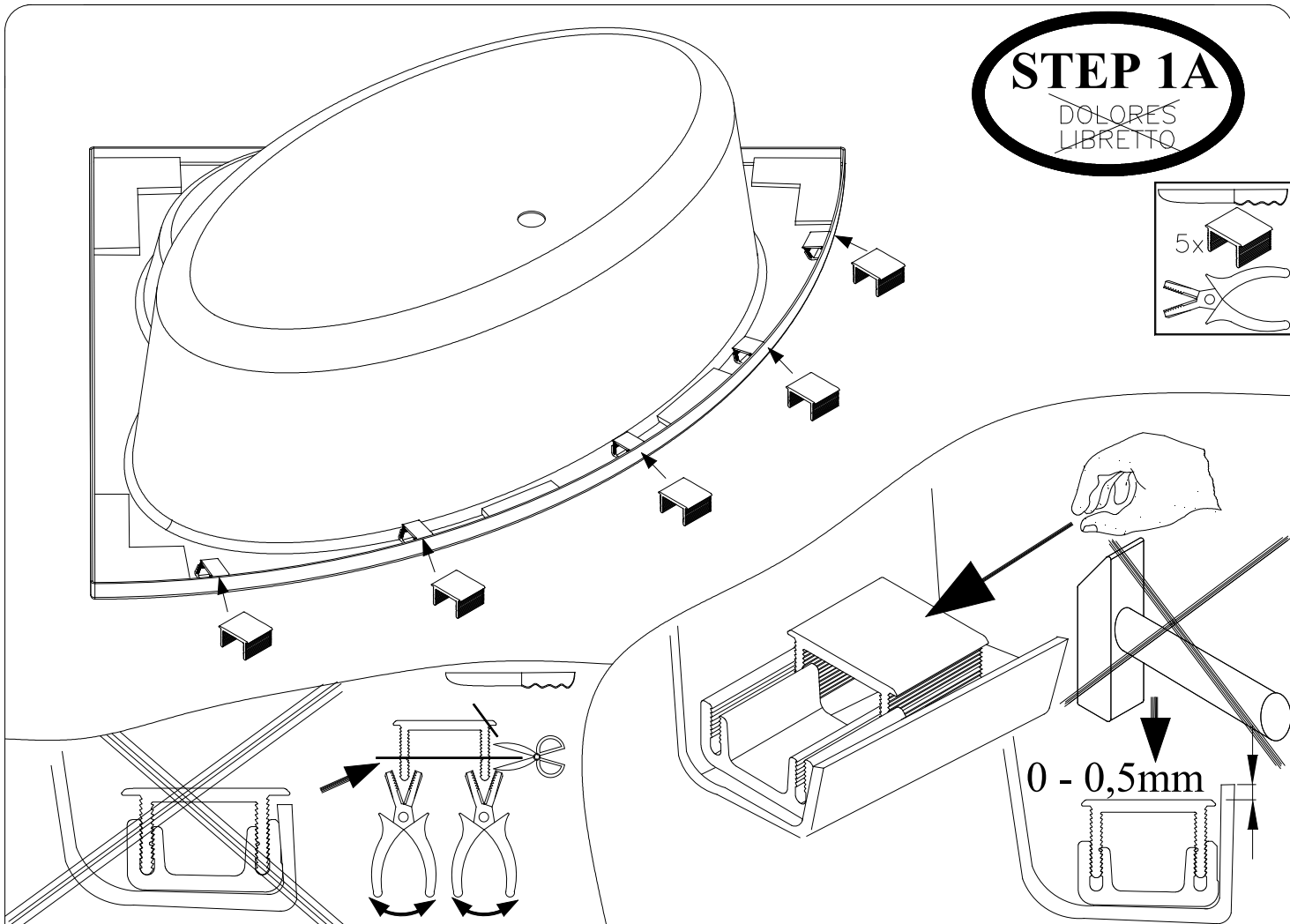

**STEP 2A**

DOLORES  
LIBRETTO

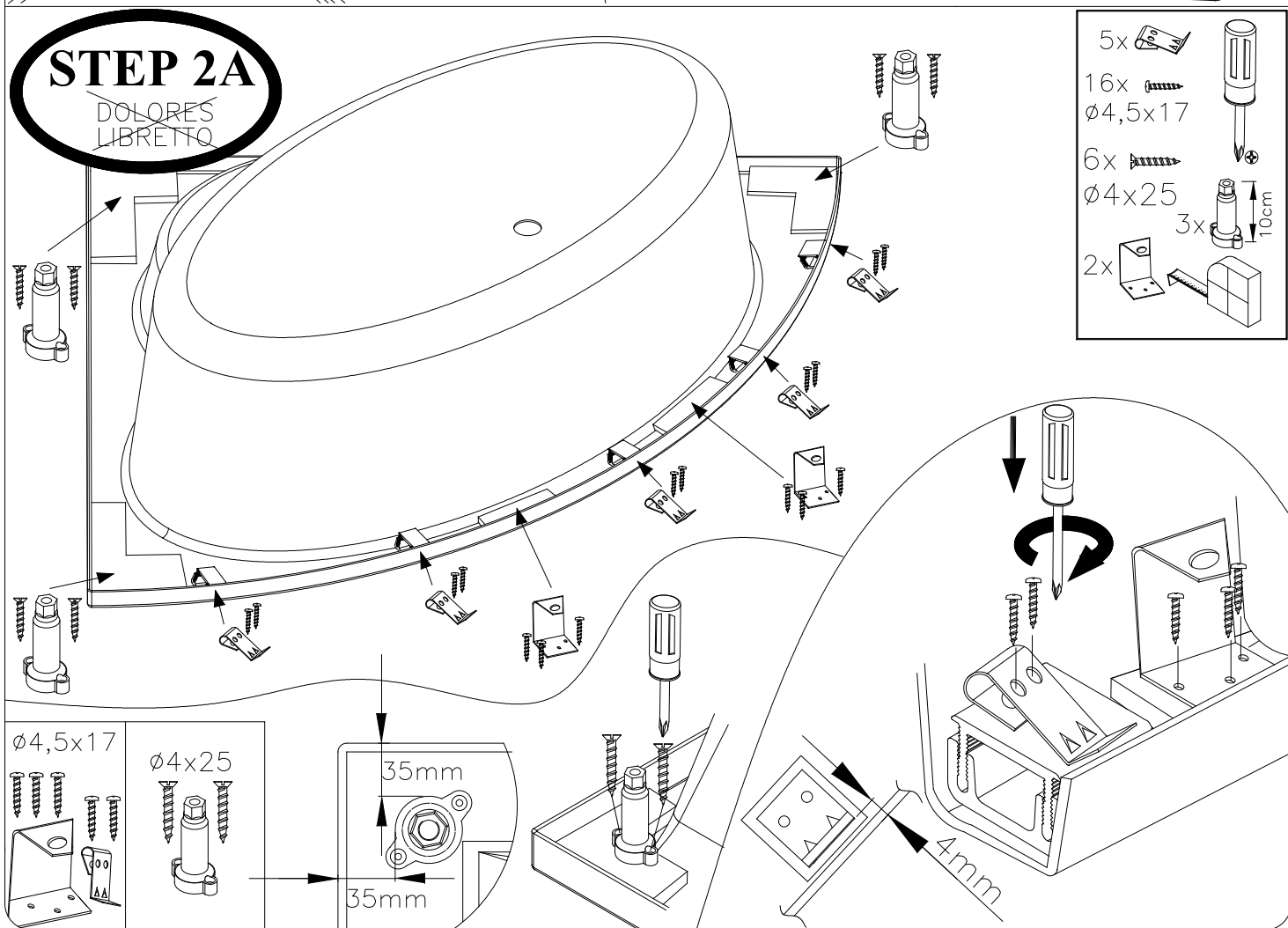

- 5x
- 16x Ø4,5x17
- 6x Ø4x25
- 3x 10cm
- 2x

Ø4,5x17

Ø4x25

35mm

35mm

4mm



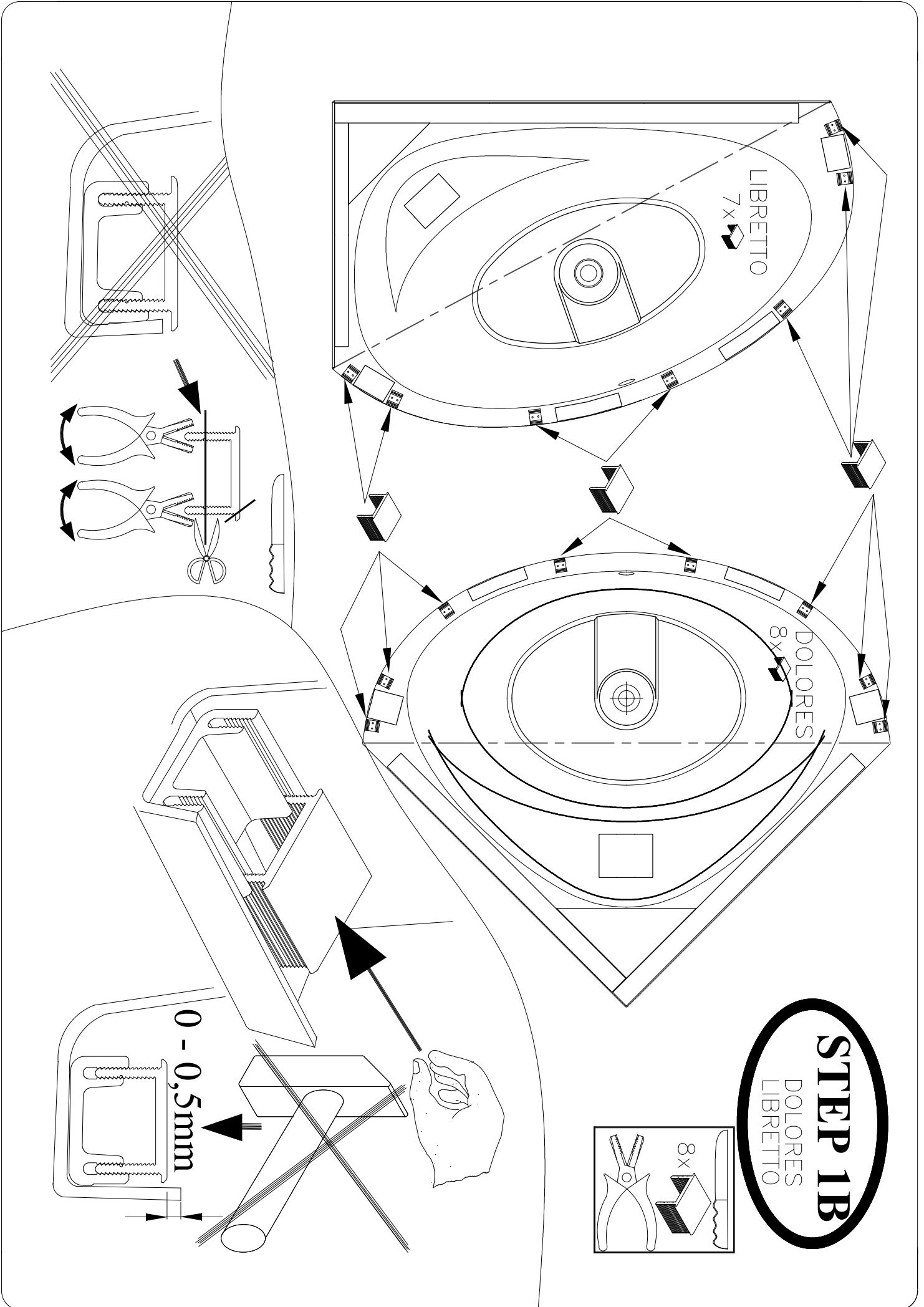

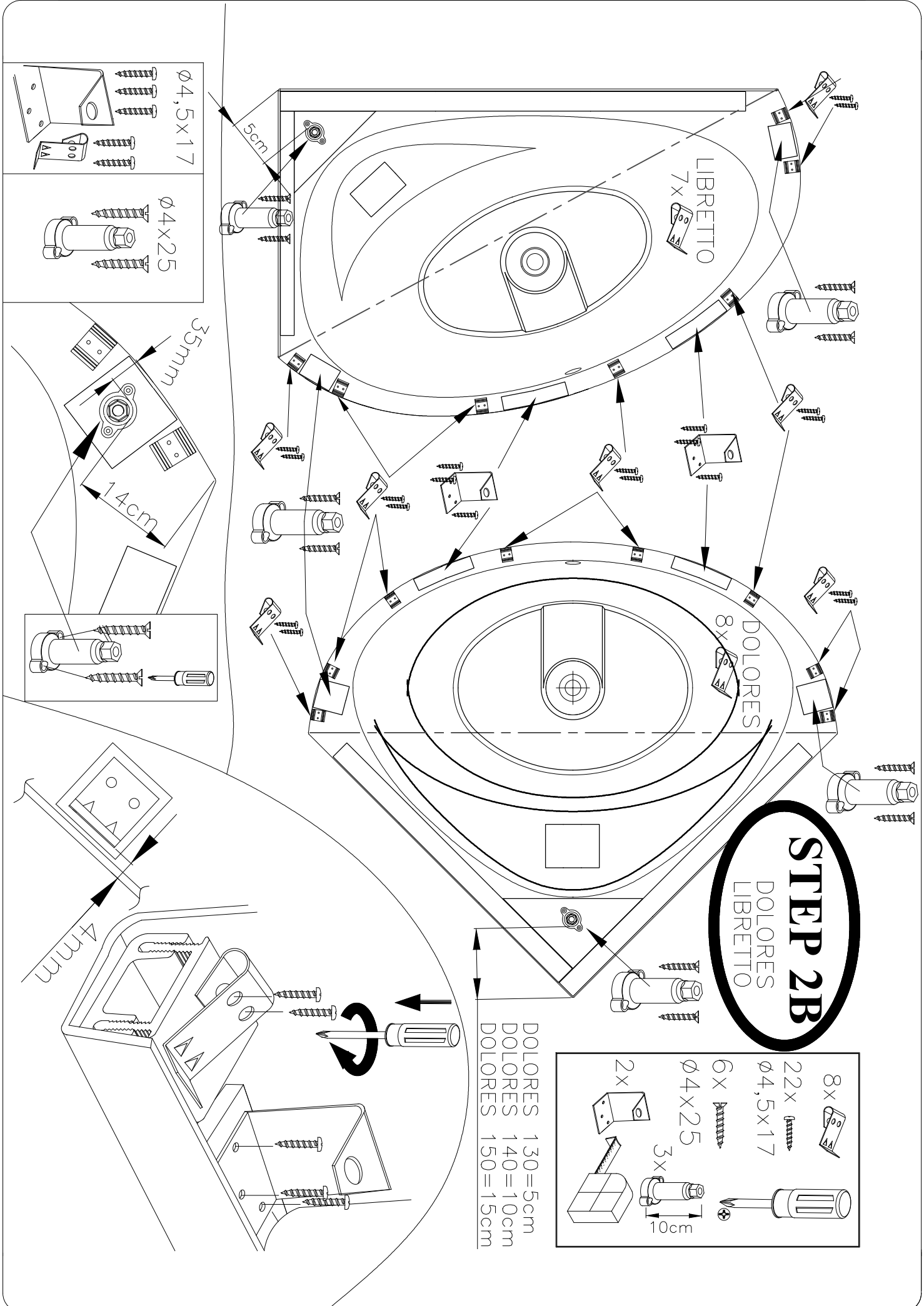

$\phi 4,5 \times 17$

$\phi 4 \times 25$

35mm  
 14cm

4mm

**STEP 2B**  
DOLORES  
LIBRETTO

- DOLORES 130=5cm
- DOLORES 140=10cm
- DOLORES 150=15cm

8x AA  
 22x  $\phi 4,5 \times 17$   
 6x  $\phi 4 \times 25$   
 2x  $\phi 4 \times 25$   
 3x 10cm

**STEP 3**

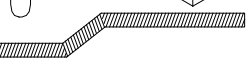
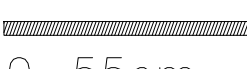

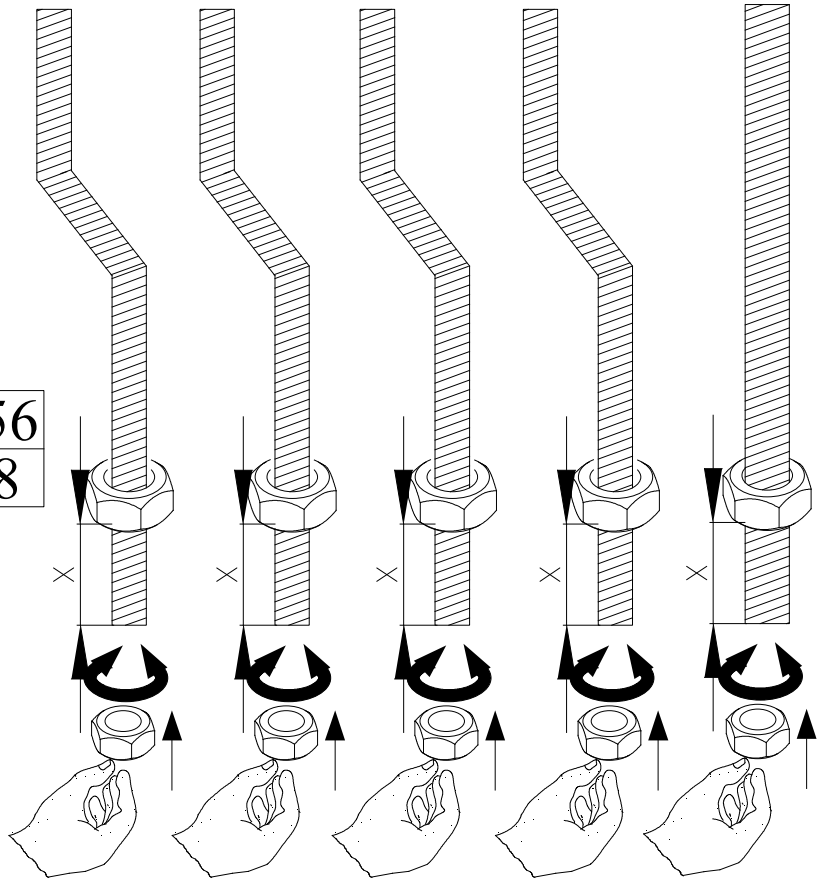
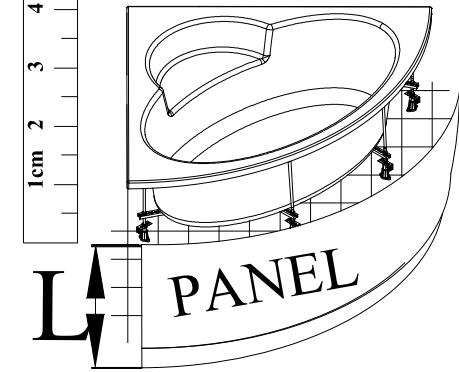

- 5x  M10
- 4x  M10-55cm
- 1x  M10-55cm

L cm	64	63	59	57	56
	X cm	1	1,5	5	7

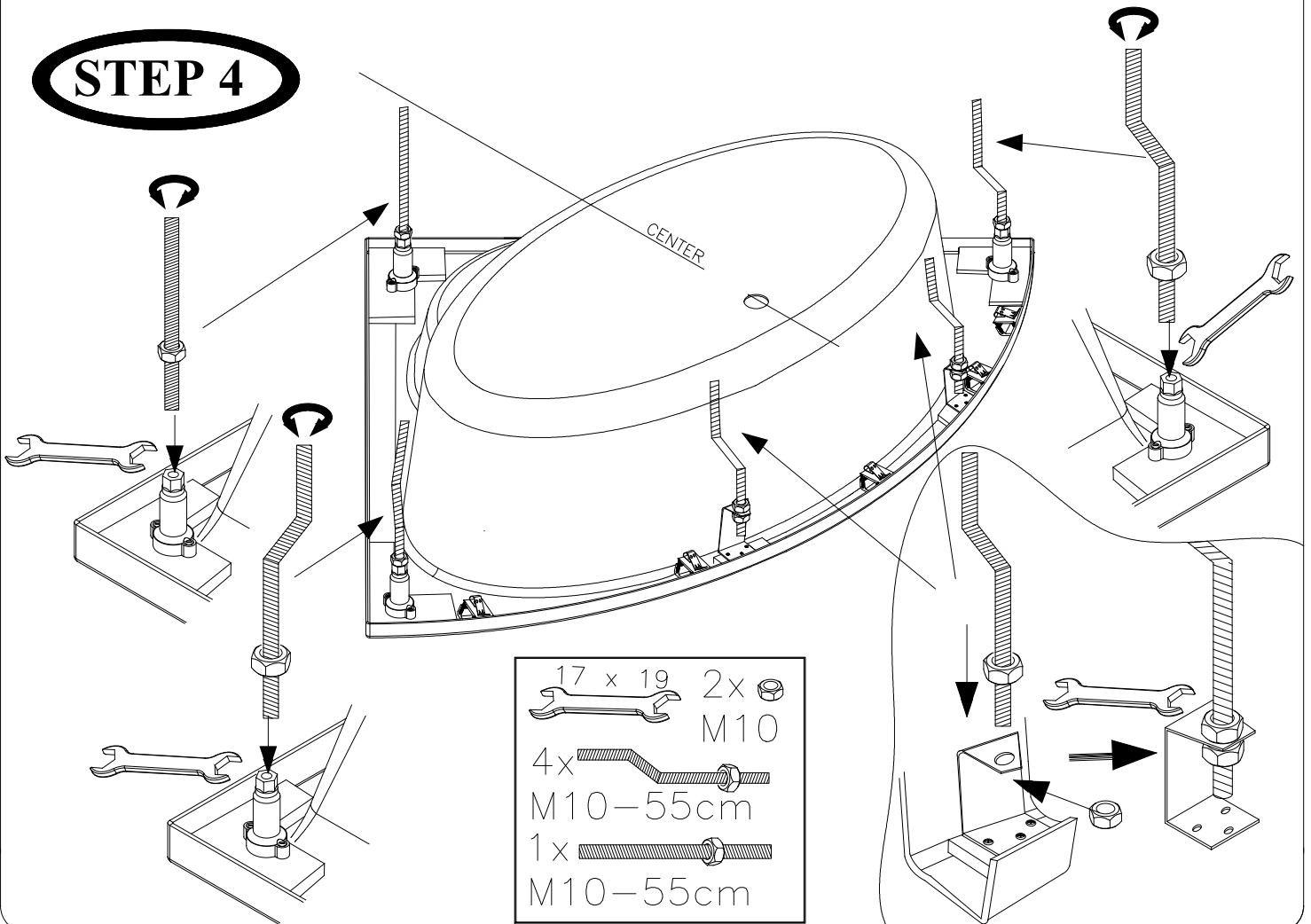

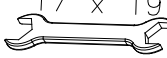

**STEP 4**





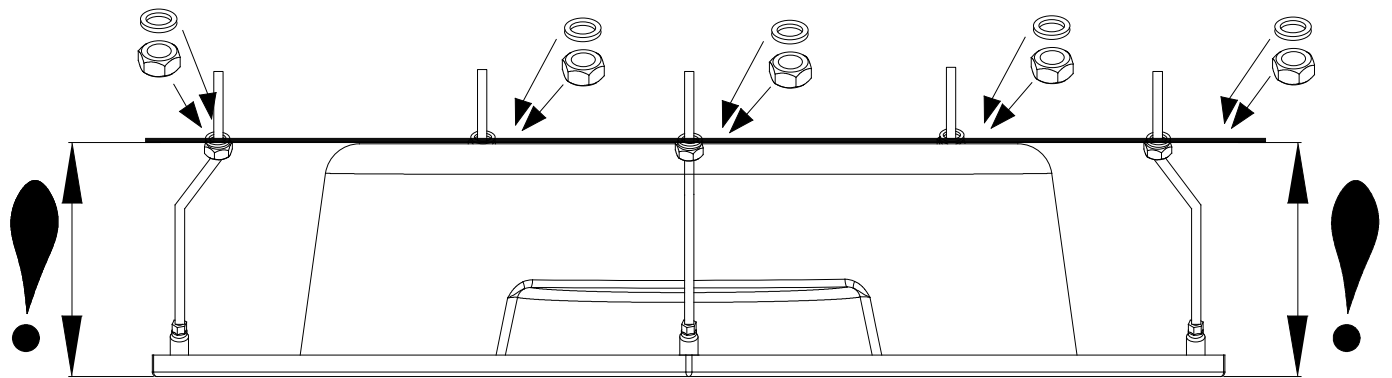

-  17 x 19 2x  M10
- 4x  M10-55cm
- 1x  M10-55cm

**STEP 5**

- |  |  |
|--|--|
| 5x  | 5x  |
| Ø12  | M10  |



**STEP 6**

- |  |  |   |  |   |
|--|--|---|--|---|
| 5x  | 5x  | 1x 80cm  | 2x 60cm  | 2x 40cm  |
| Ø12  | M10  |   |  |   |

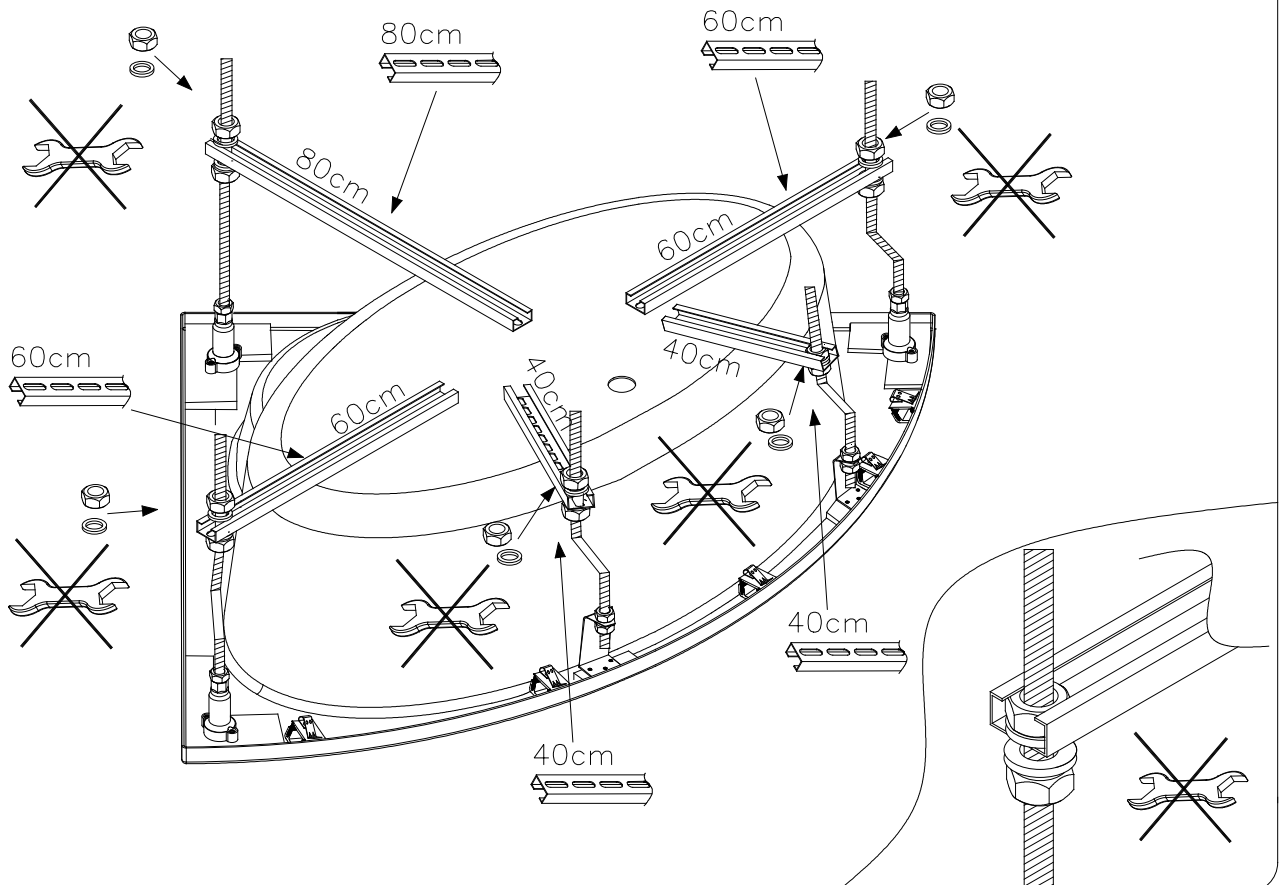

**STEP 7**

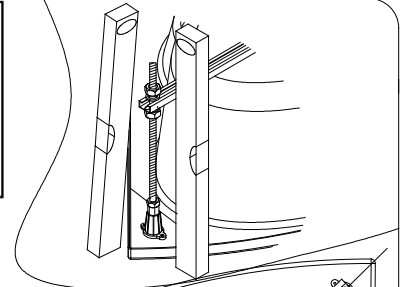
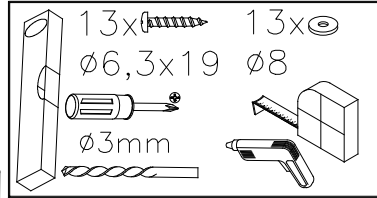
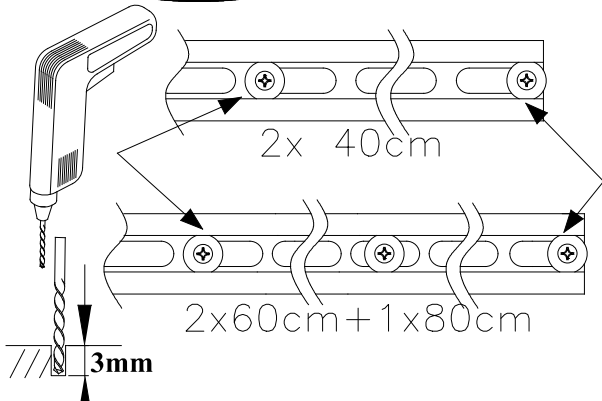

**STEP 7b**

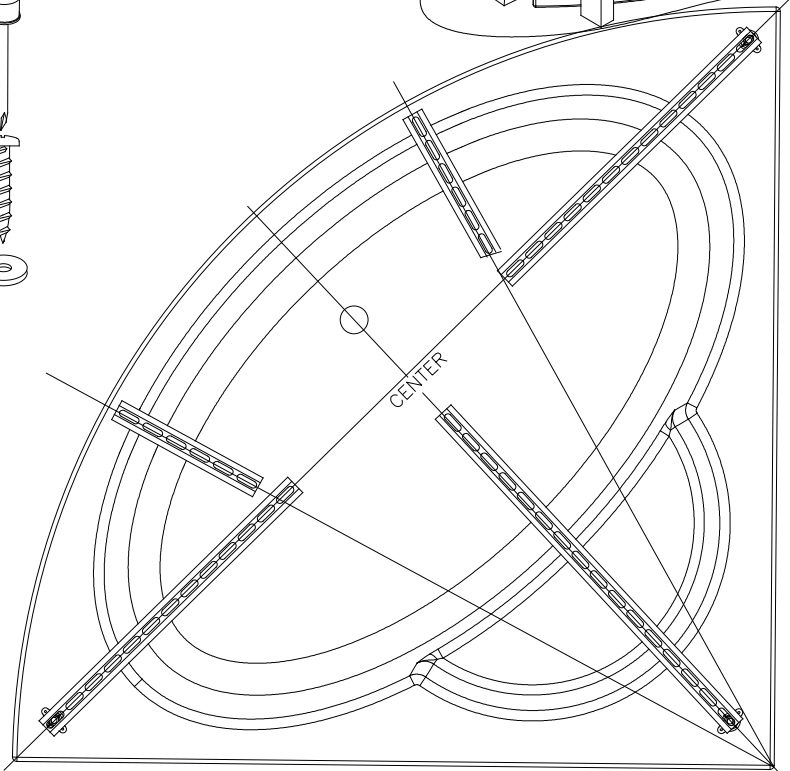
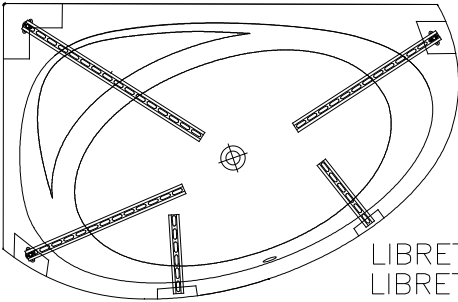

**STEP 8b**

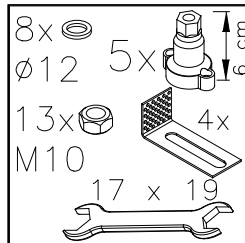
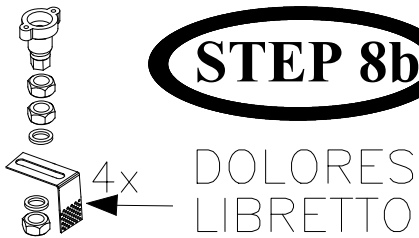

**STEP 8**

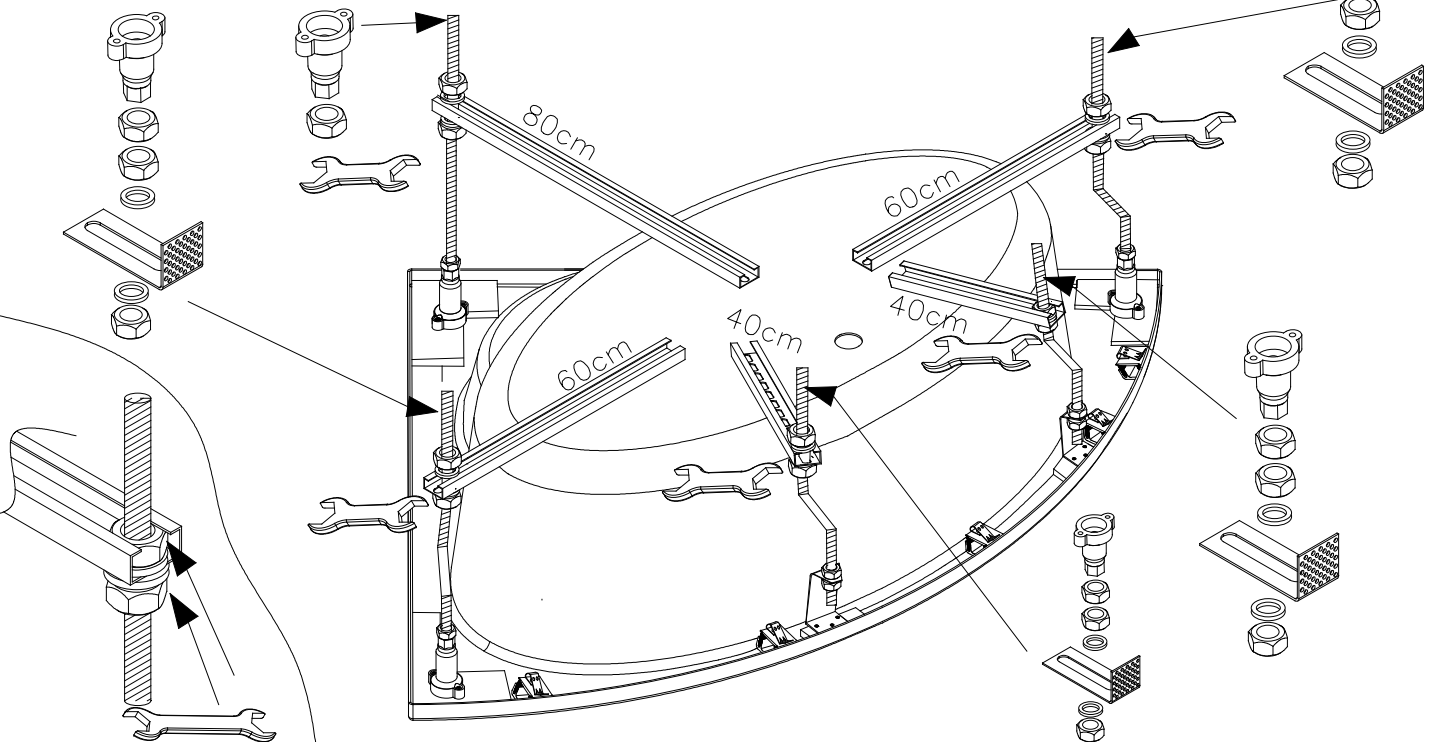

**STEP 9**

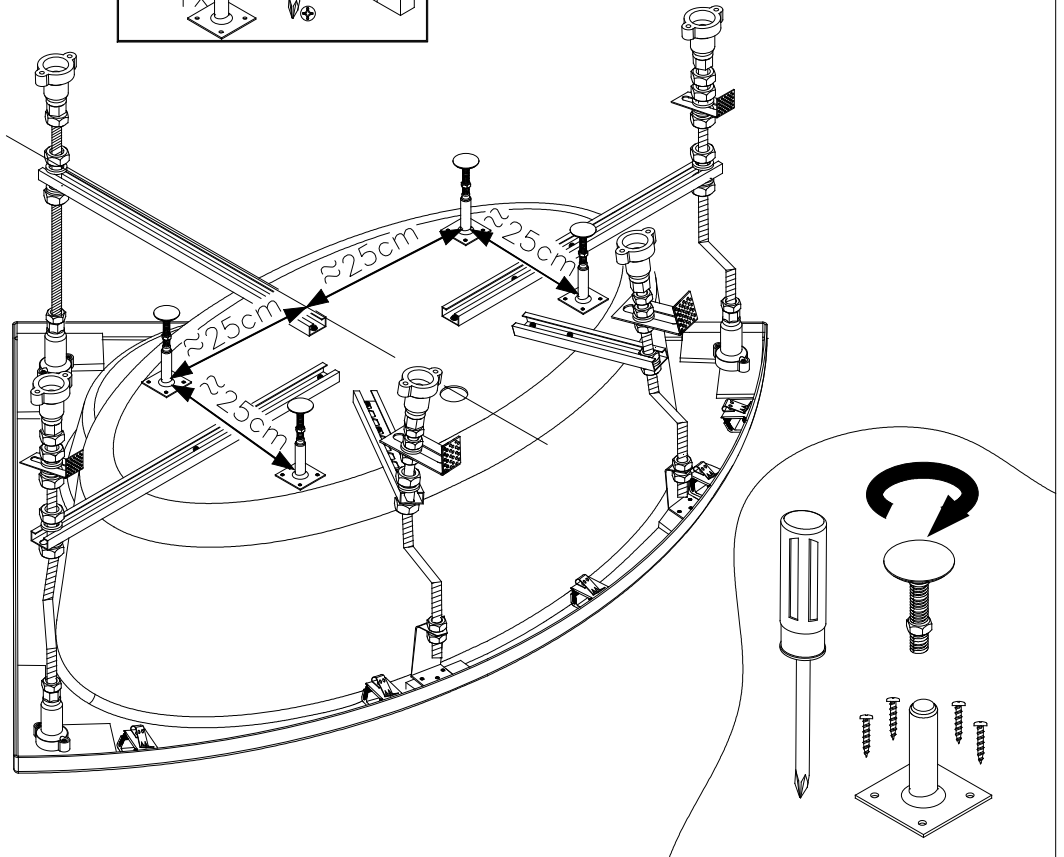
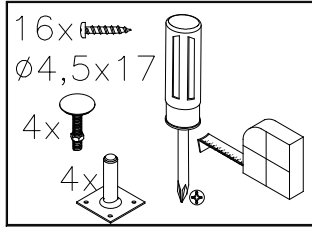

**STEP 10**

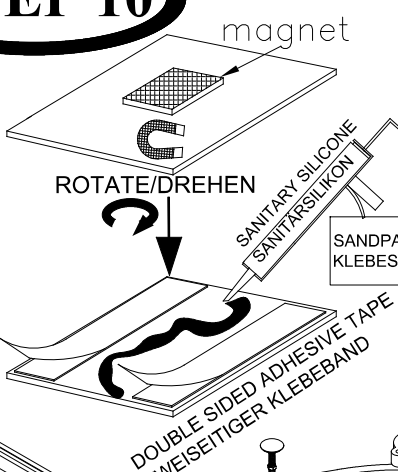
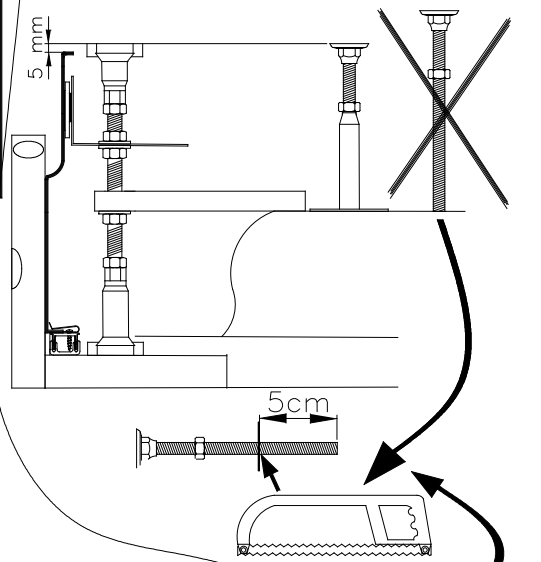
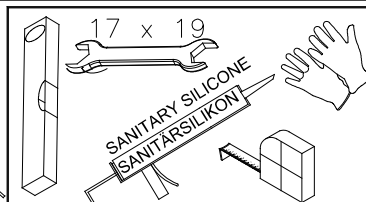

SANDPAPER AND CLEAN THE ADHESION SURFACE  
KLEBESTELLE REINIGEN UND ABSCHLEIFEN

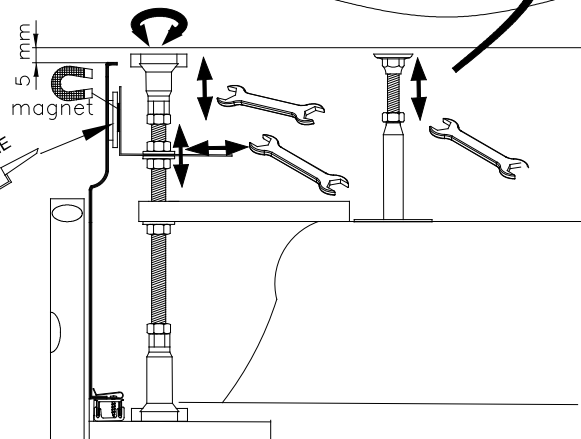
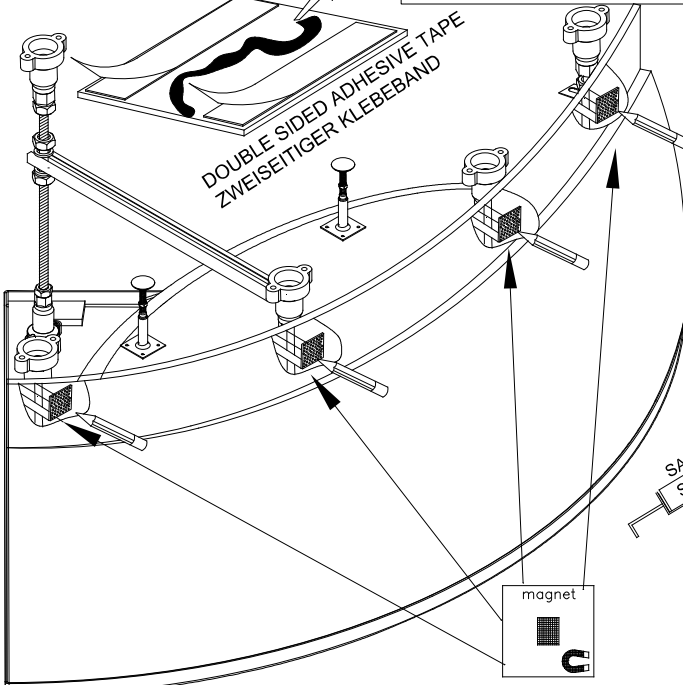

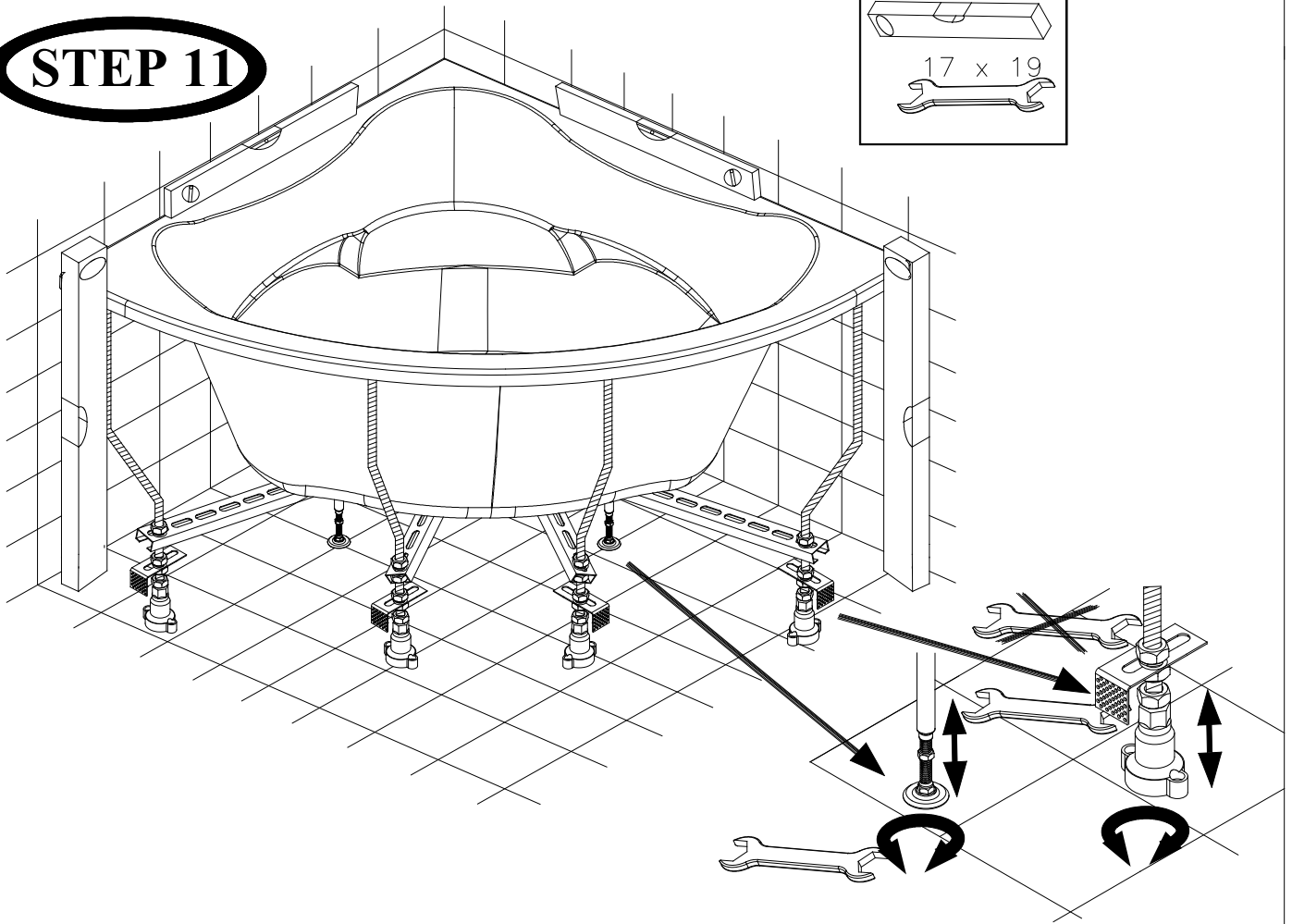

**STEP 11**

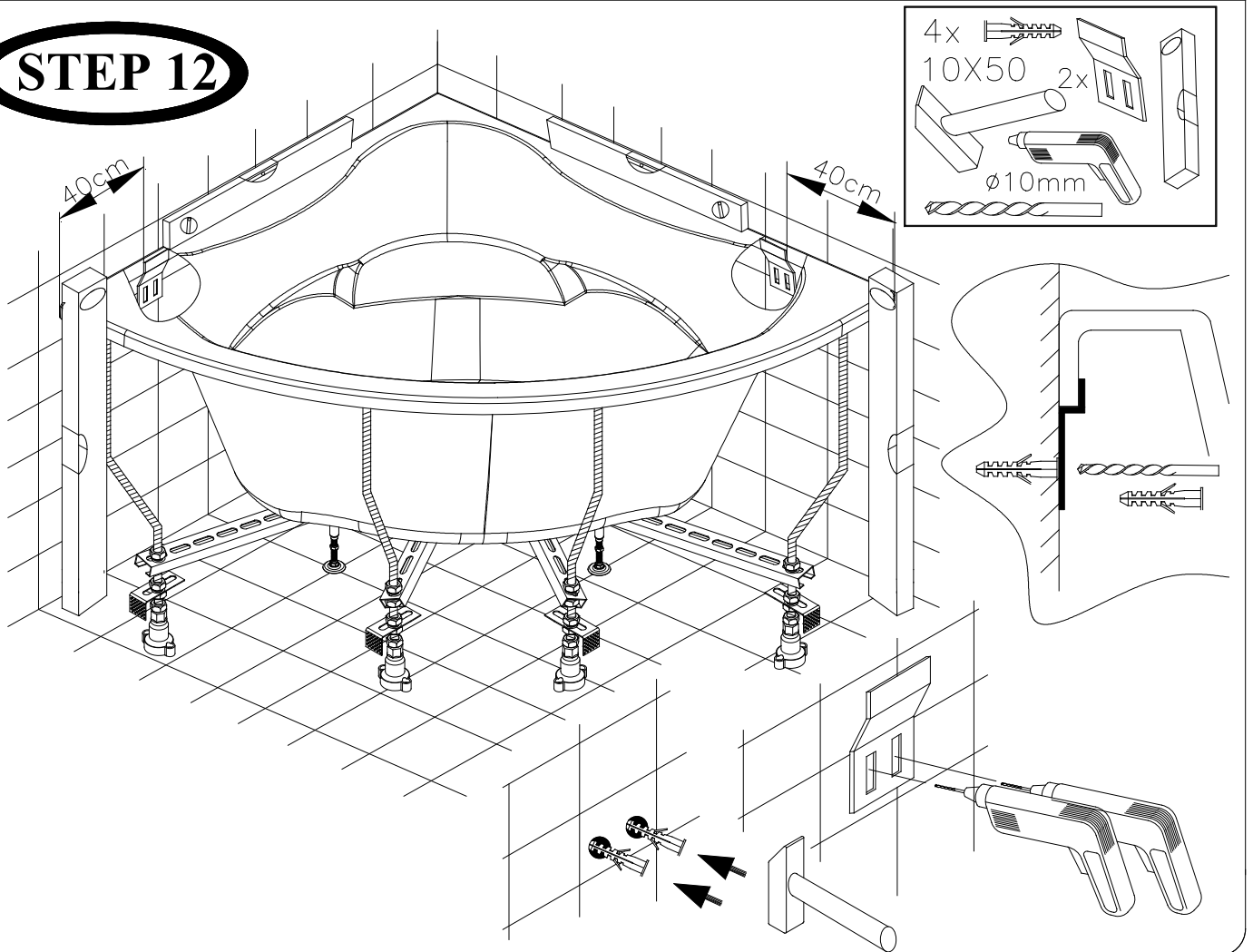

**STEP 12**



**STEP 13**

4x  4x   
8X50 Ø8

13 

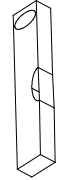
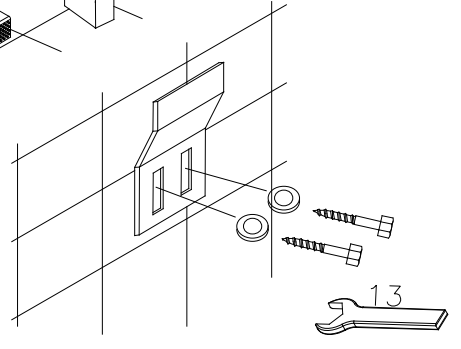
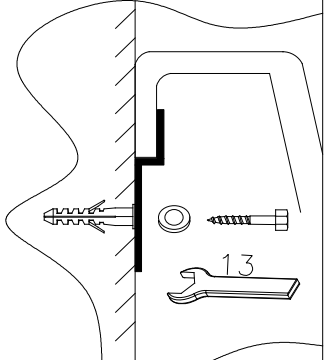
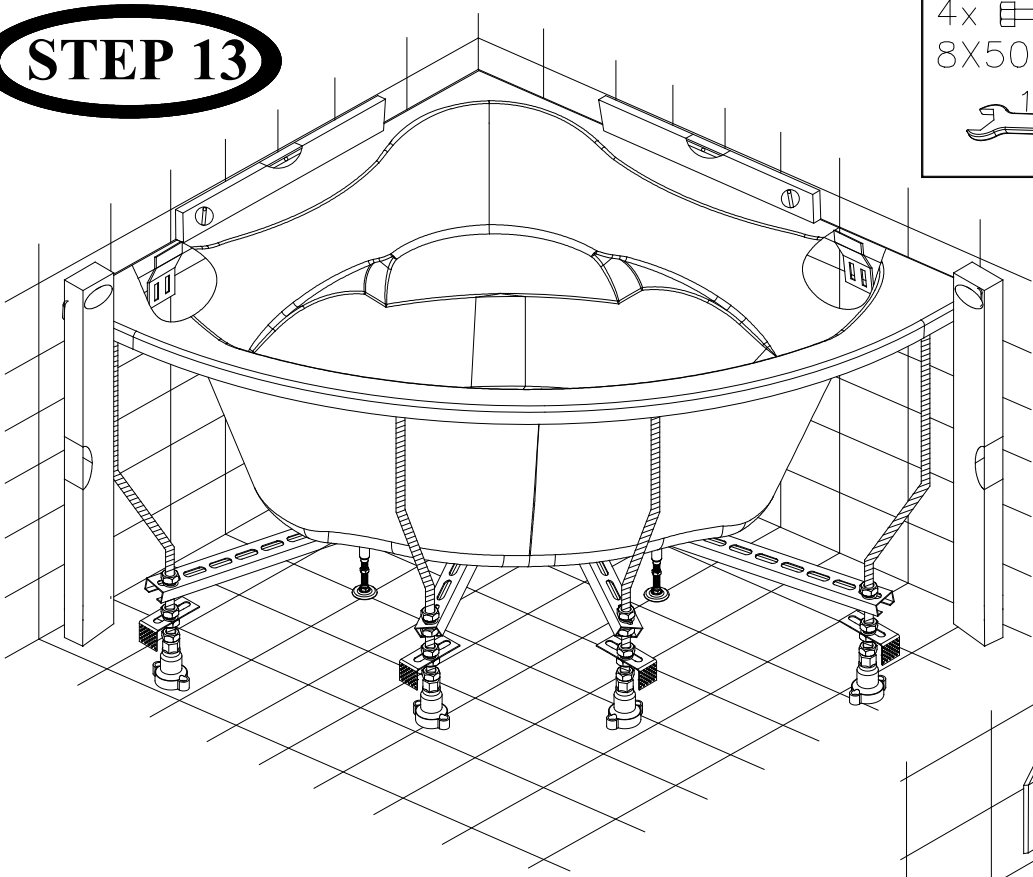
**STEP 14**

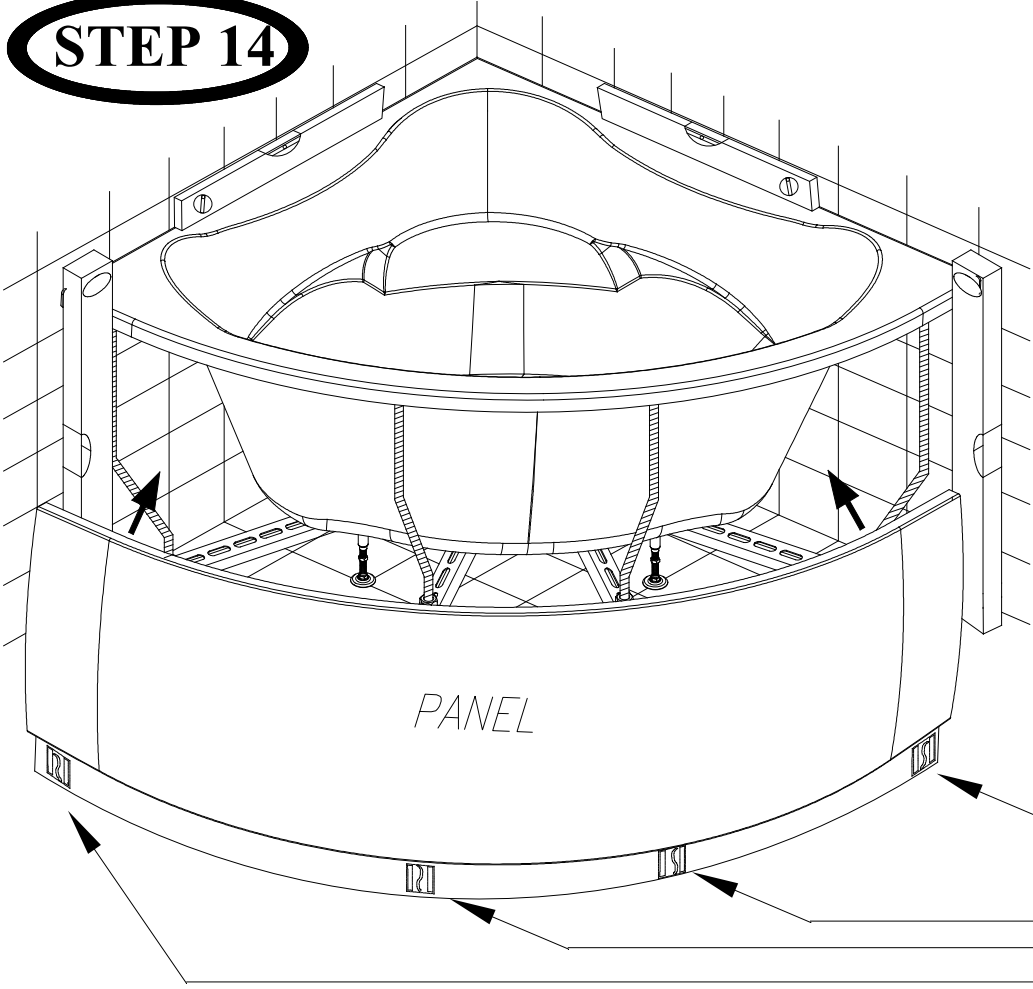
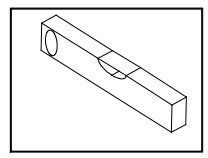

magnet

